

PRP4x6(NF/GR/WH)

V.6

Aufbauanleitung

DE - Bevor Sie beginnen:

- Es ist empfehlenswert sich etwas Zeit zu nehmen, um die Aufbauanleitung zu lesen, bevor mit dem Aufbau begonnen wird.
- Der Aufbau sollte in der vorgegebenen Reihenfolge erfolgen.
- Die Aufbauanleitung dient lediglich als Richtschnur für den Aufbau. Nicht alle Schritte sind im Detail vorgegeben.
- Bitte prüfen Sie alle Teile auf Vollständigkeit und Zustand vor dem Aufbau. Der Aufbau sollte durch mindestens 2 Personen erfolgen.
- Bei starkem Wind sollte der Aufbau nicht erfolgen.
- Bohren Sie die Teile vor, wo es angezeigt wird.
- Wir empfehlen, das Gerätehaus erst nach weitgehendem Aufbau vor Anbringung der Deckleisten mit Farbe oder Holzlasur zu behandeln, da sich die Elemente bei einer einseitigen Behandlung verziehen können, wodurch der Aufbau erschwert werden könnte.

Instructions d'assemblage

FR - Avant de commencer:

- Avant de commencer le processus d'assemblage, veuillez s'il vous plaît vous familiariser parfaitement avec les instructions.
- La maison doit être assemblée suivant la séquence indiquée dans les instructions.
- Les instructions s'entendent comme lignes directrices, toutes les étapes ne sont pas décrites en détails.
- Avant de commencer l'assemblage, vérifier tous les éléments.
- Deux personnes sont nécessaires au minimum pour l'assemblage.
- Ne pas tenter d'assembler la maison dans des conditions de vents forts.
- Percer les trous dans les éléments suivant les marques.

Montage-instructie

NL - Alvorens te beginnen:

- Voordat u begint met de montage raden wij u aan de handleiding grondig door te lezen.
- Bij de montage van het huis dient u de volgorde zoals deze in de handleiding is aangegeven te volgen.
- De handleiding is bedoeld als richtsnoer, niet alle stappen zijn in detail uitgewerkt.
- Vóór de montage dienen alle details gecontroleerd te worden.
- De montage van het huis dient door tenminste twee personen uitgevoerd te worden.
- Het huis nooit in harde wind opbouwen.
- Gat en onderdelen boren, waar dit staat aangegeven.

Pokyny k montáži

CZ - Než začnete:

- Než začnete s montáží, seznámte se důkladně s těmito pokyny.
- Domek musí být sestaven v pořadí uvedeném v pokynech.
- Pokyny slouží pouze jako vodítko, ne všechny kroky jsou zde popsány dopodrobna.
- Než začnete s montáží, zkontrolujte všechny díly.
- K montáži jsou zapotřebí minimálně dvě osoby.
- Nepokoušejte se smontovat domek za silného větru.
- Vyvrtejte do dílů otvory podle značek.

Pokyny pre montáž

SK - Predtým, než začnete:

- Predtým, než začnete montovať, sa, prosím, dôkladne oboznámte s týmito pokynmi.
- Dom je potrebné zmontovať podľa poradia uvedeného v pokynoch.
- Tieto pokyny poskytujú návod, nepopisujú však detailne všetky kroky.
- Predtým, než začnete montovať, skontrolujte všetky časti.
- Pri montáži sú potrební najmenej dvaja ľudia.
- Nepokúšajte sa montovať dom pri silnom vetre.
- Otvory v jednotlivých častiach vyvrátajte podľa označenia.

1.

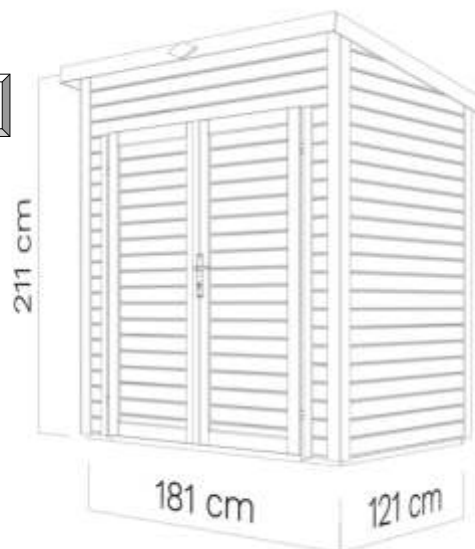

2.

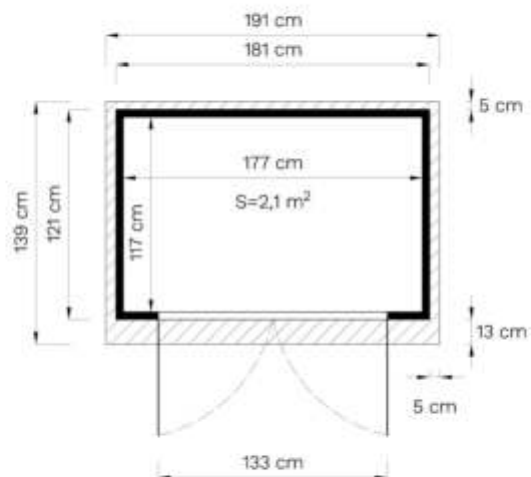
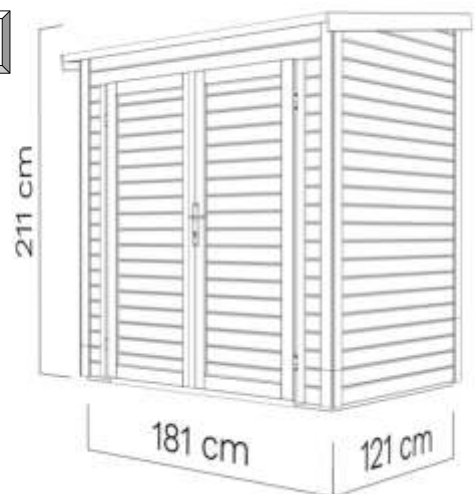

DE - Technische Änderungen vorbehalten.











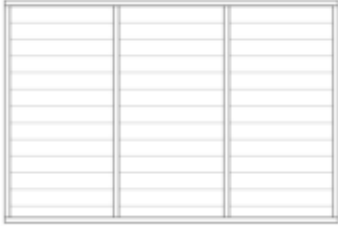
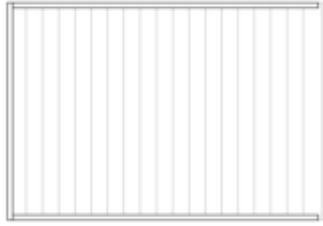

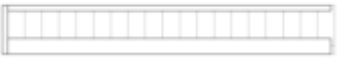



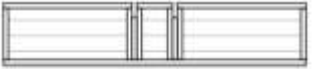
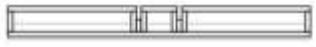

Alle Maße sind ca. Maße.

EN - Technical modifications reserved.

















All dimensions are approximate dimensions.

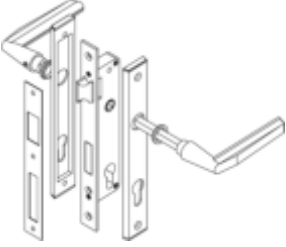
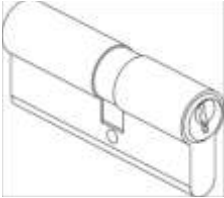
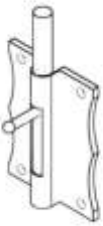

PRP4x6(NF/GR/WH)

ID	Details in mm (Tolerance/Toleranz ...+ 2mm)	Pcs.	ID	Details in mm (Tolerance/Toleranz ...+ 2mm)	Pcs.
237	47 x 1174 x 1770 	x 1	244	47 x 1174 x 1703 	x 3
245	47 x 540 x 1703 	x 1	46	32 x 672x 1685 Left door 	x 1
249	47 x 191 x 1703 	x 1	250	47 x 191 x 1703 	x 1
260	47 x 365 x 1174 	x 1	261	47 x 365 x 1174 	x 1
262	47 x 361 x 1714 	x 1	263	47 x 185 x 1714 	x 1
837	28 x 80 x 1174 	x 2	47	32 x 672 x 1685 Right door 	x 1
823	28 x 28 x 1324 	x 2	802	28 x 28 x 945 	x 4
734	19 x 45 x 1332 	x 1	651	12 x 90 x 1390 	x 2
638	12 x 90 x 967 	x 2	623	12 x 70 x 1680 	x 9
603	12 x 70 x 360 	x 4	601	12 x 70 x 180 	x 4
738	19 x 45 x 1680 	x 4	717	19 x 45 x 360 	x 2

PRP4x6(NF/GR/WH)

ID	Details in mm (Tolerance/Toleranz ...+ 2mm)	Pcs.	ID	Details in mm (Tolerance/Toleranz ...+ 2mm)	Pcs.
715	19 x 45 x 180 	x 2	589	12 x 42 x 1680 	x 3
726	19 x 45 x 728 	x 2	716	19 x 45 x 202 	x 1
536	1 x 1000 x 2000 NB! Roofing felt for initial covering! 	x 2	628	12 x 90 x 201 	x 1
1505	Ø4,5 x 50 	x 59	1506	Ø3,5 x 35 	x174
1508	Ø4 x 25 	x 30	1513	Ø3 x 10 	x103
1531		x 1	1554	ES60 (30/30) 	x 1
1517		x 2	1528		x 4
679	12 x 230 x 1150 Roof panel 	x 1	678	12 x 230 x 830 Roof panel 	x 2
676	12 x 230 x 230 Roof panel 	x 1	516	12 x 830 x 1150 Roof panel 	x 2

NB!

Empfohlen bei Aufbau auf besonders feuchtem Untergrund. **(Nicht im Lieferumfang enthalten!)**

Recommended for assembly on moist ground. **(Not included!)**

* Unterlegpads /

* Patio Pads

Min. 7 lfm/rm



+€

* Imprägniert Kantholz /

* Impregnated beam

40*60*1770 mm

4 Stck/Pcs



+€

* Schraube /

* Screw

4,5*70 mm

16 Stck/Pcs



+€

Fundamentplan / Foundation Plan

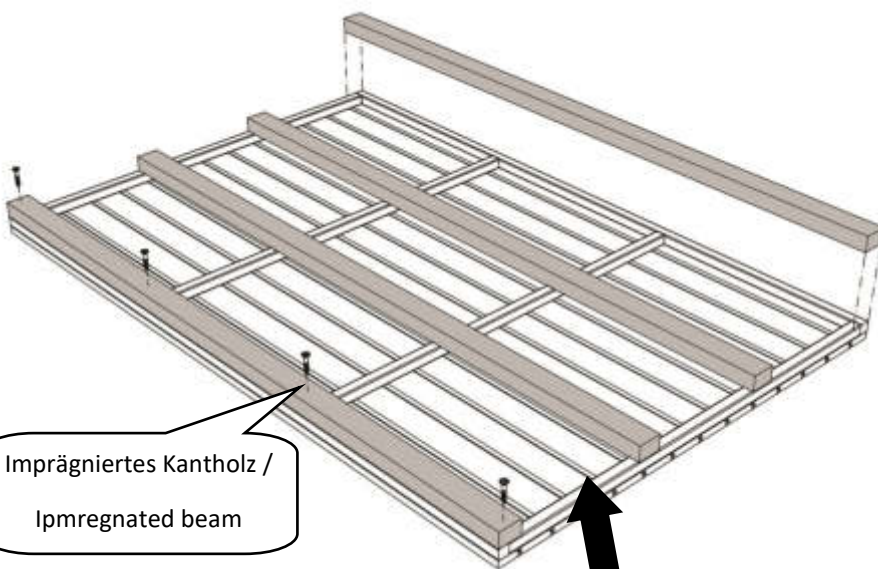
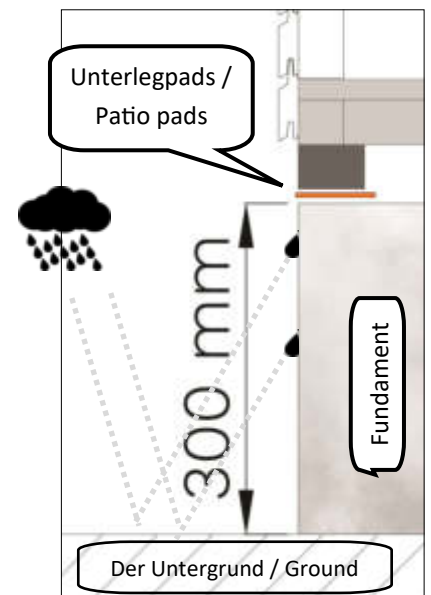
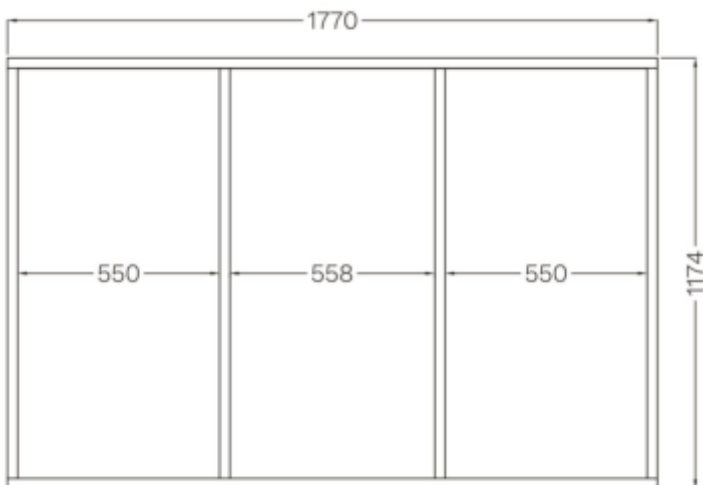

Imprägniertes Kantholz /
Impregnated beam

Holzschutzmittel /
Wood preservative



Vor dem Aufbau!

Bitte erkundigen Sie sich vor der Montage, ob für den Bau eine Genehmigung erforderlich ist.

Before installation!

Prior to assembly please check whether a permit is required.

PRP4x6(NF/GR/WH)

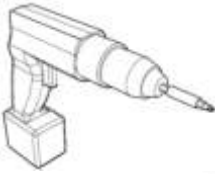

Ø 4 mm

Ø 8 mm



1.

237

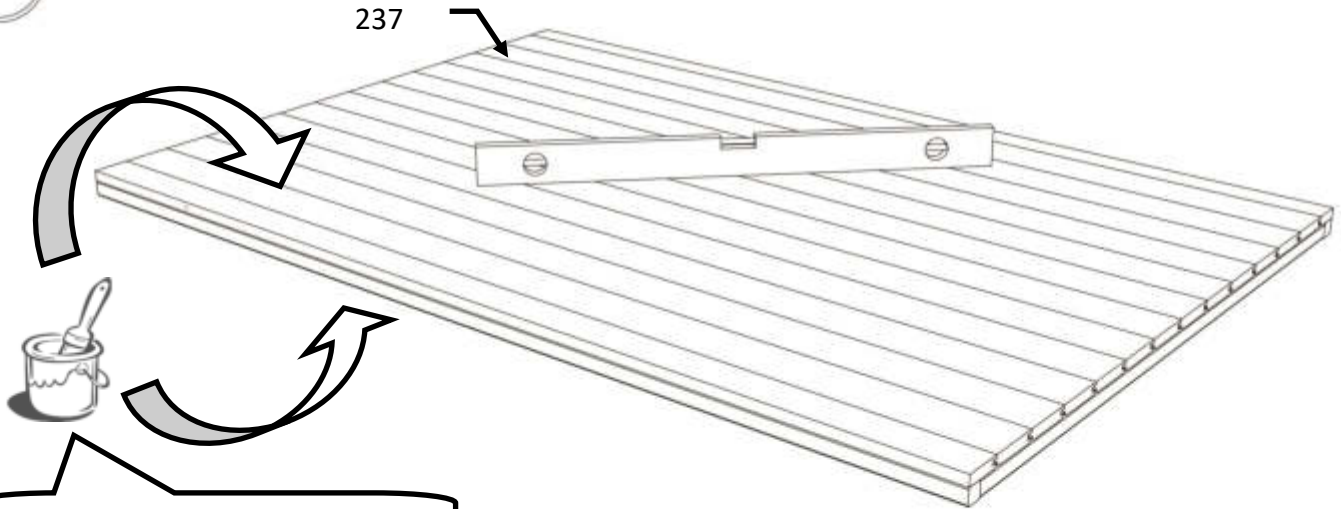

Holzschutzmittel / Wood preservative

2.

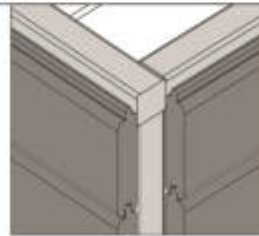
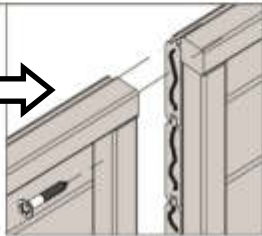

3.

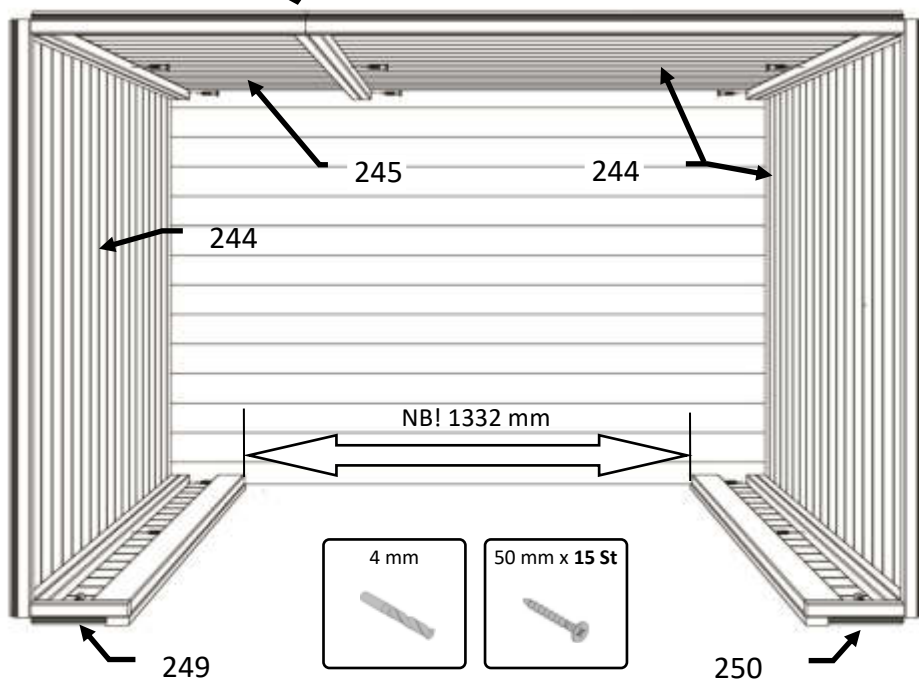

4 mm

50 mm x 15 St

249

250

PRP4x6(NF/GR/WH)

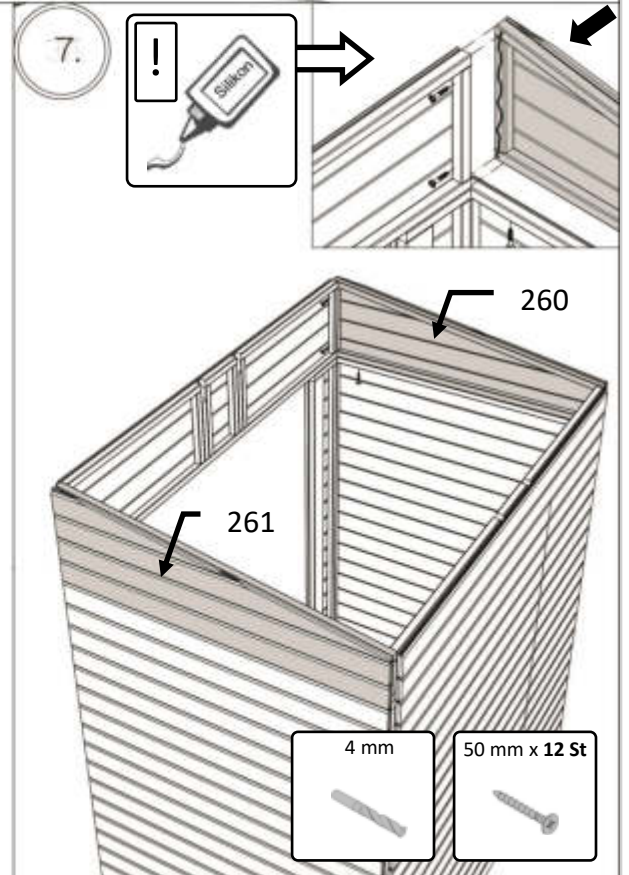
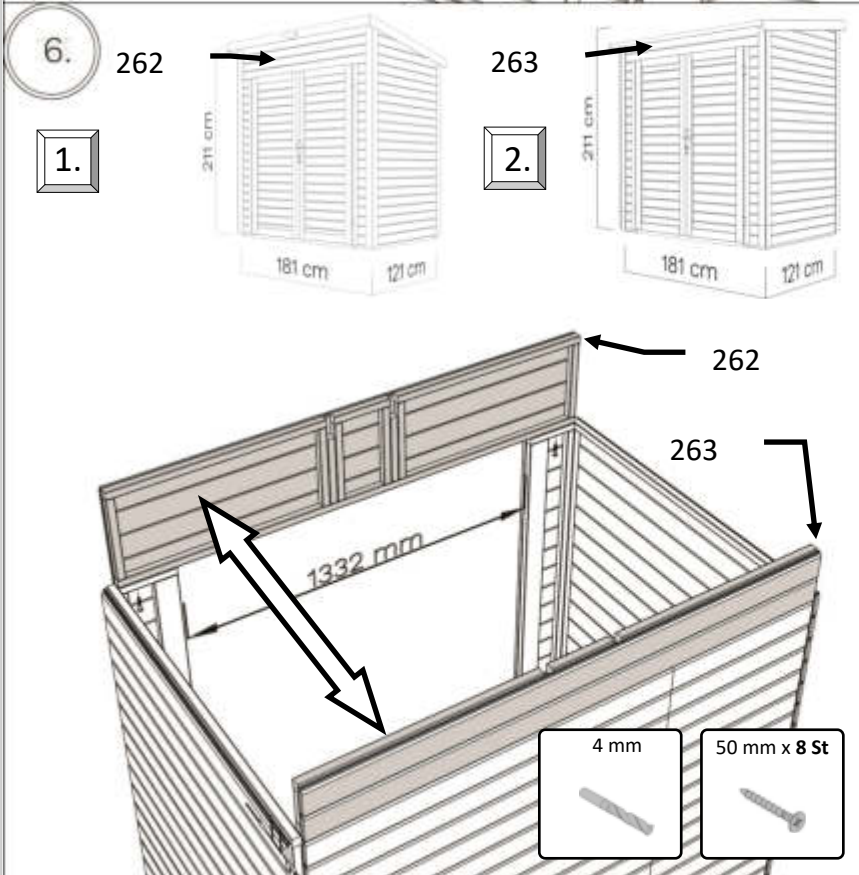
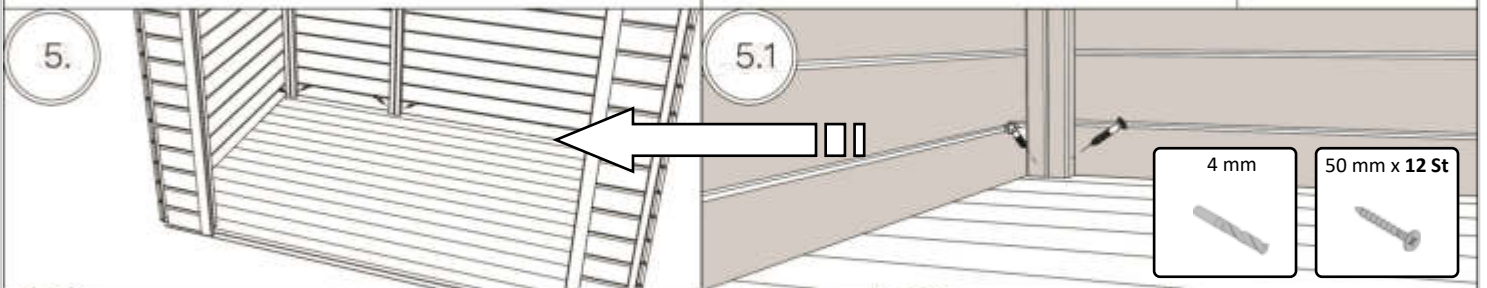
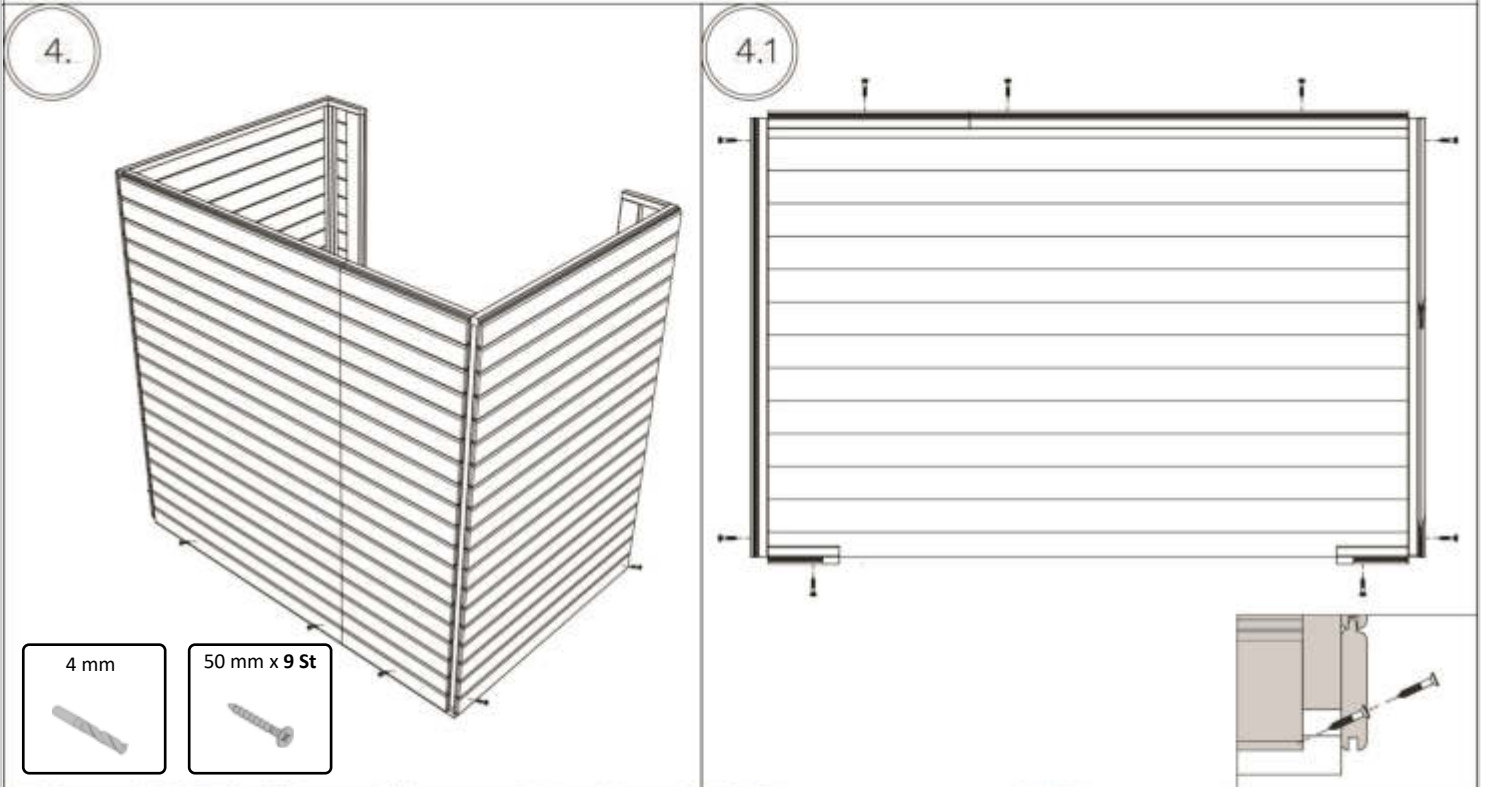

PRP4x6(NF/GR/WH)

8.

837

4 mm

50 mm x 4 St

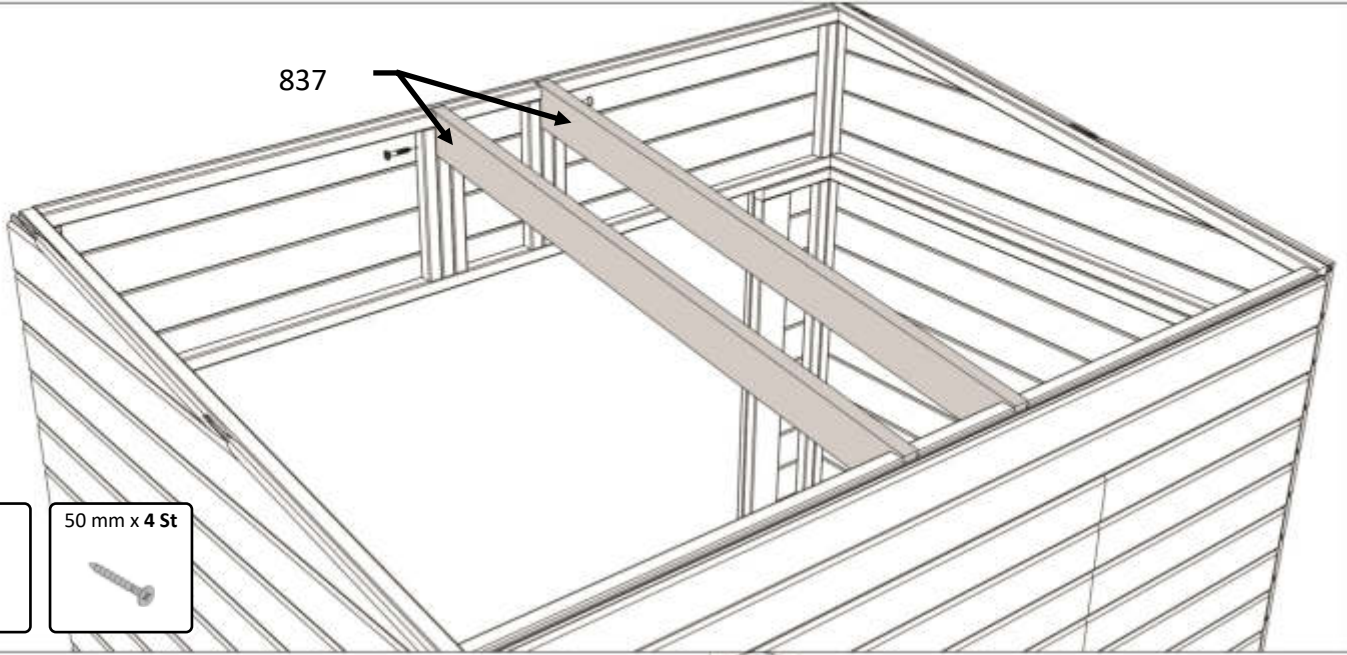

9.

676

678

35 mm x 10 St

678

802

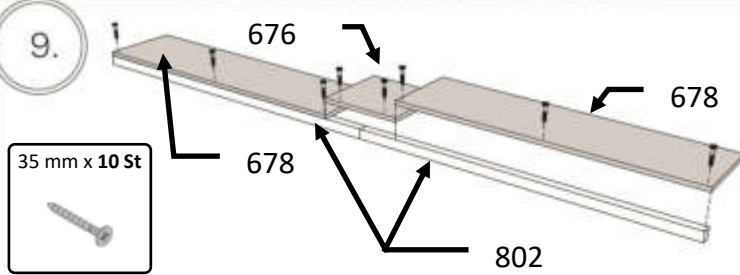

10.1

41 mm

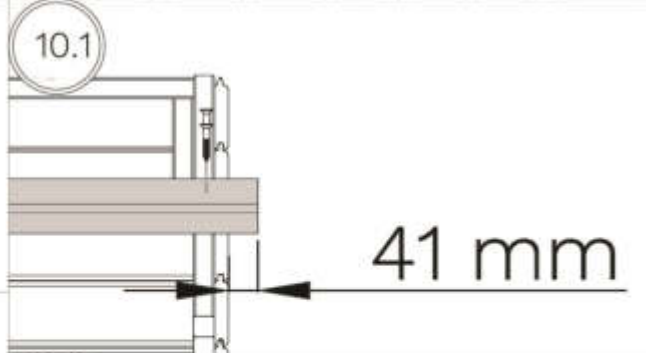

10.

35mm x 12 St

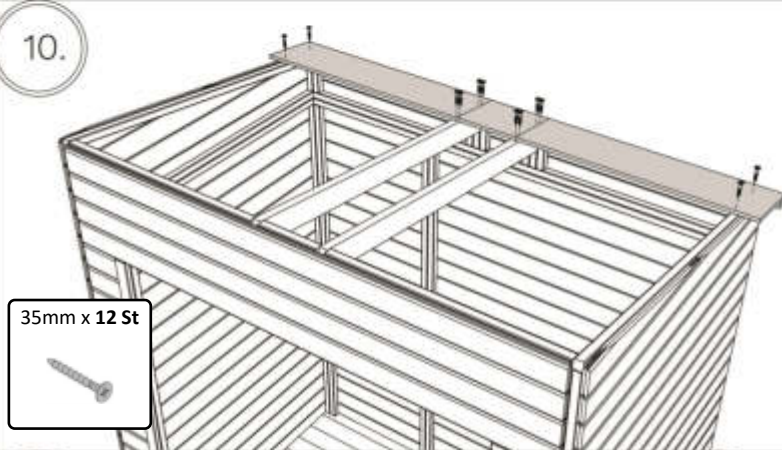

10.2

41 mm

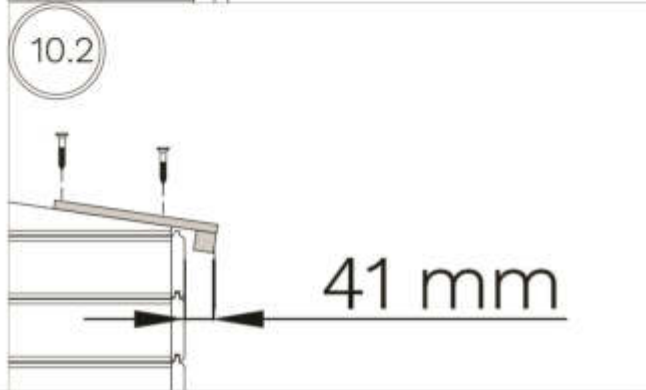

11.

679

35 mm x 6 St

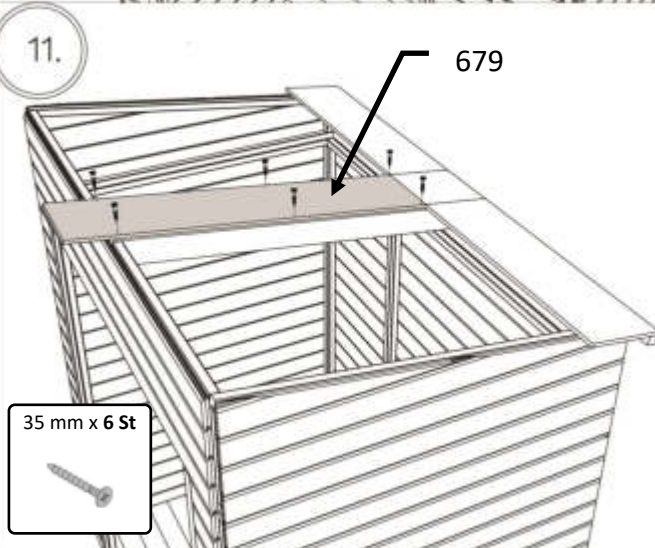

12.

516

35 mm x 12 St

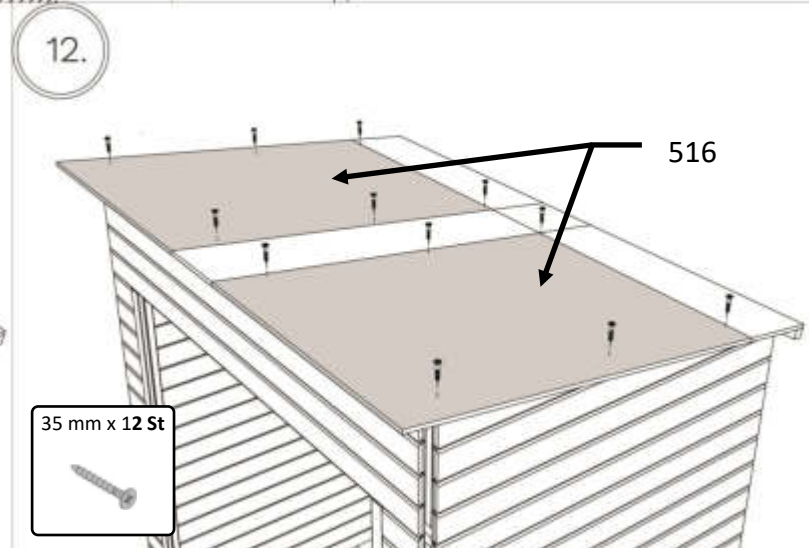

PRP4x6(NF/GR/WH)

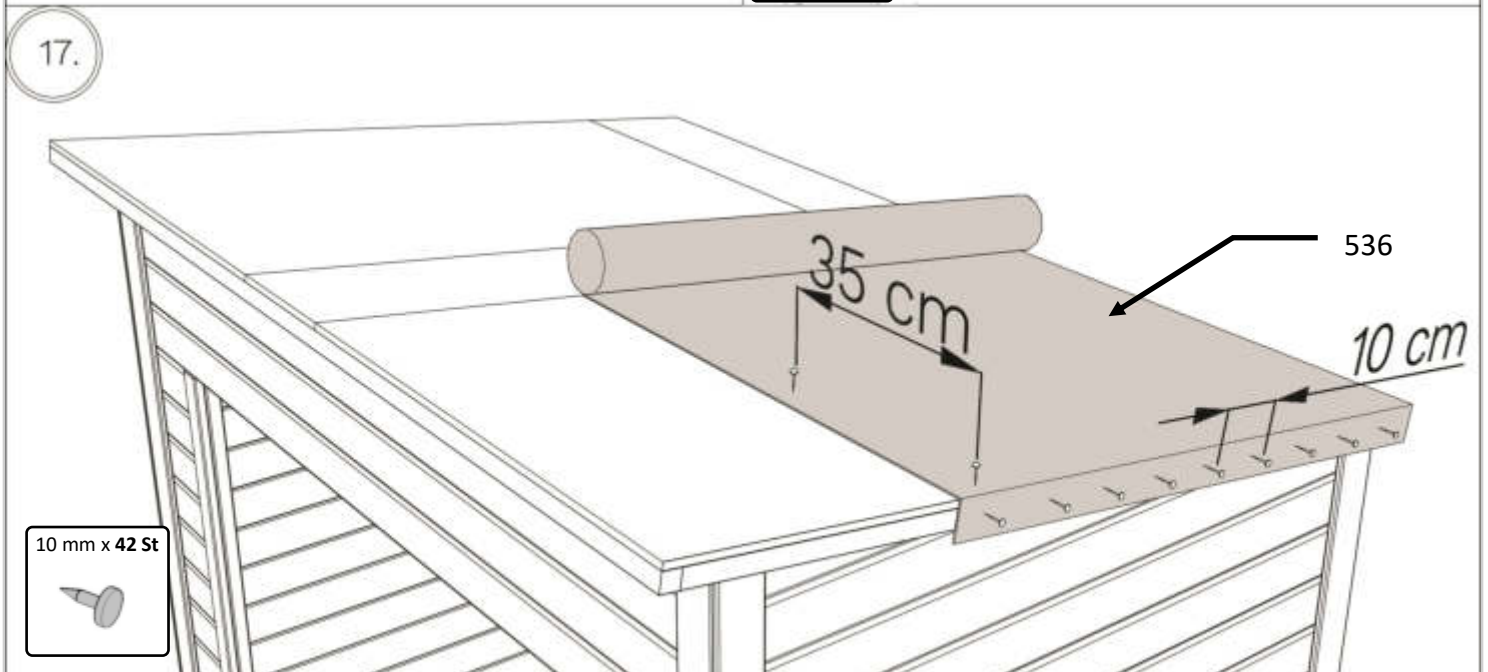
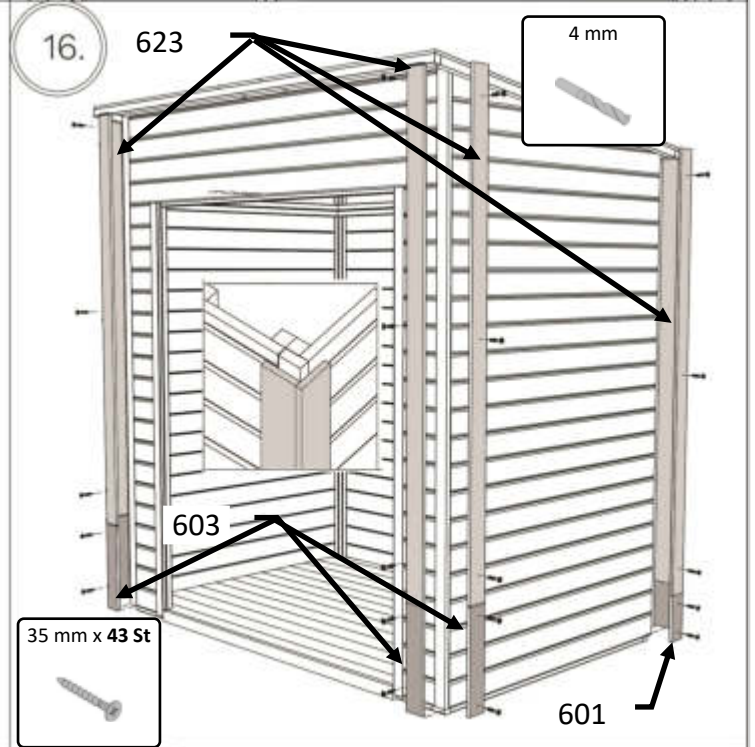
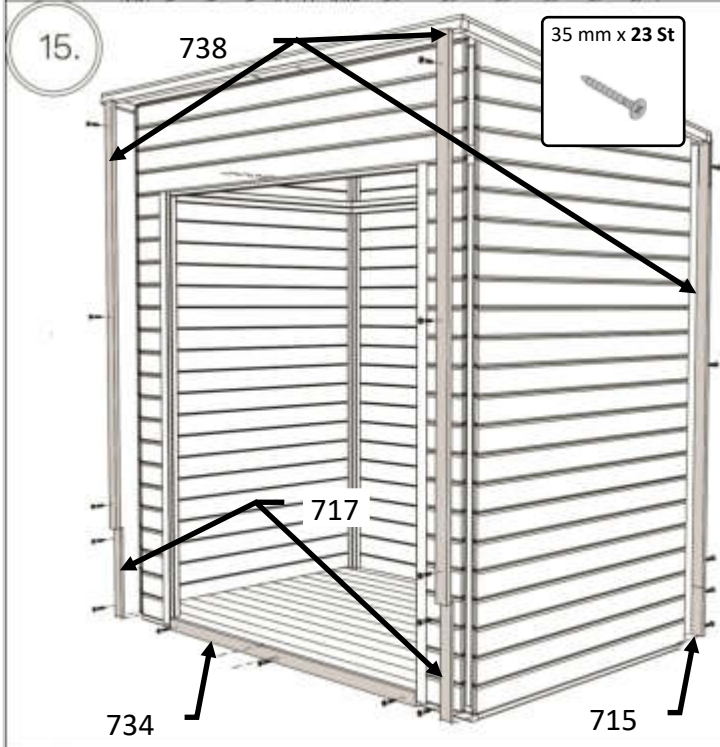
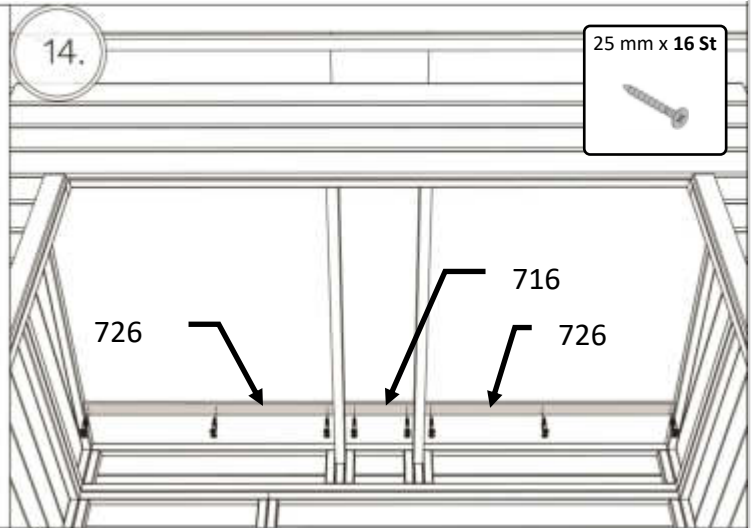
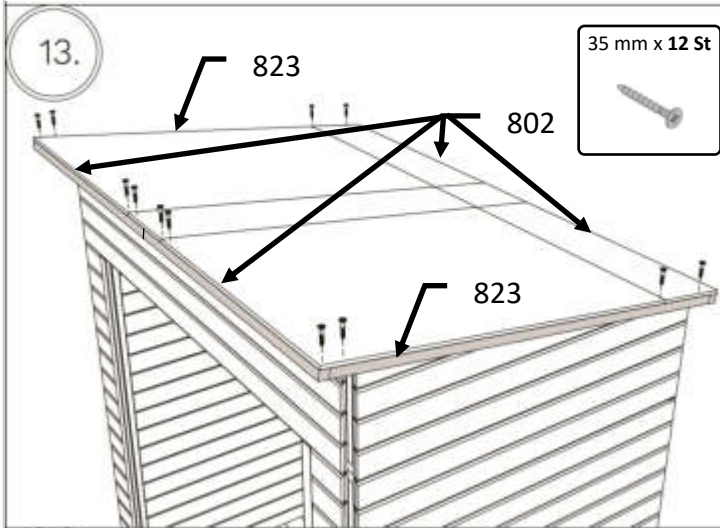

PRP4x6(NF/GR/WH)

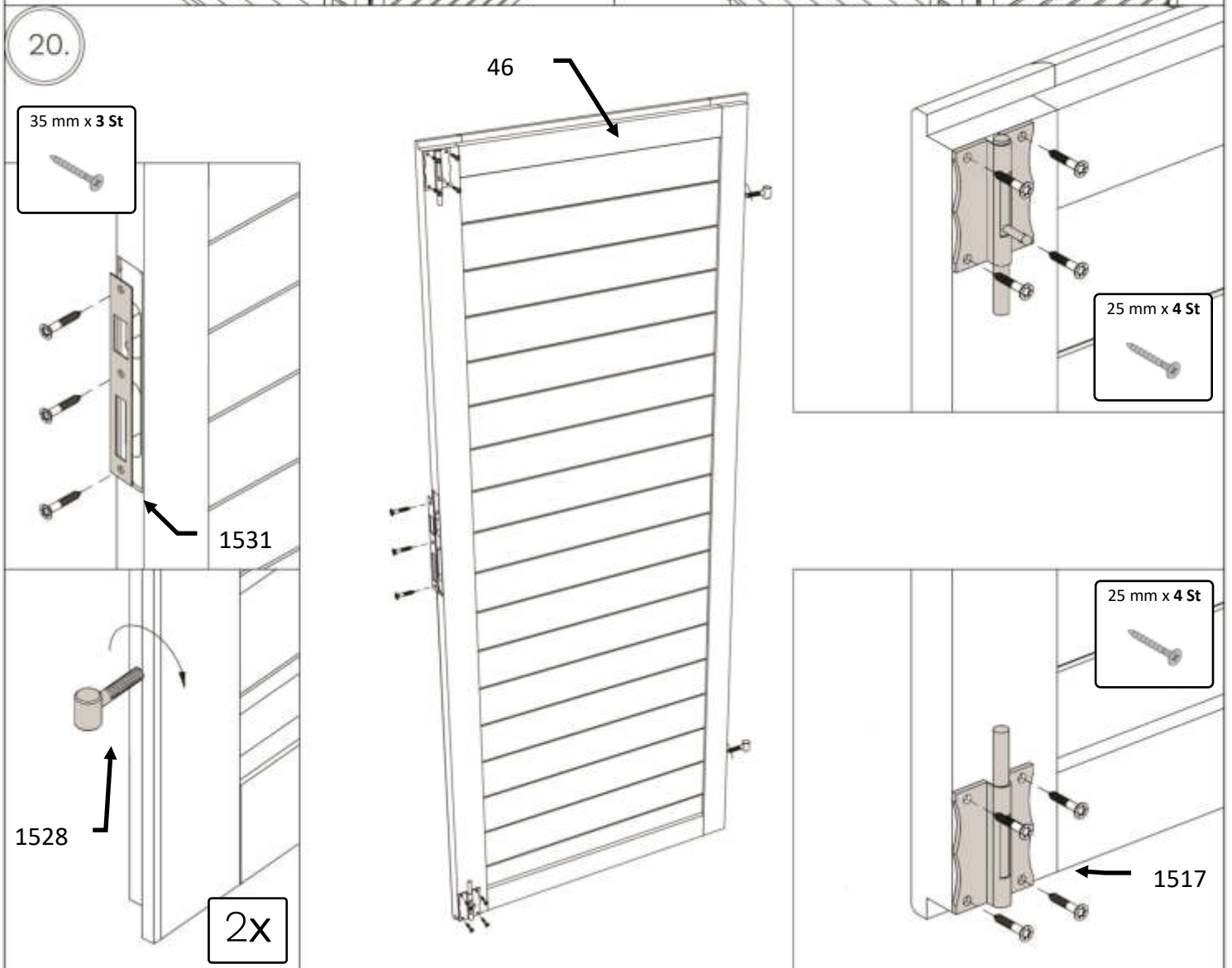
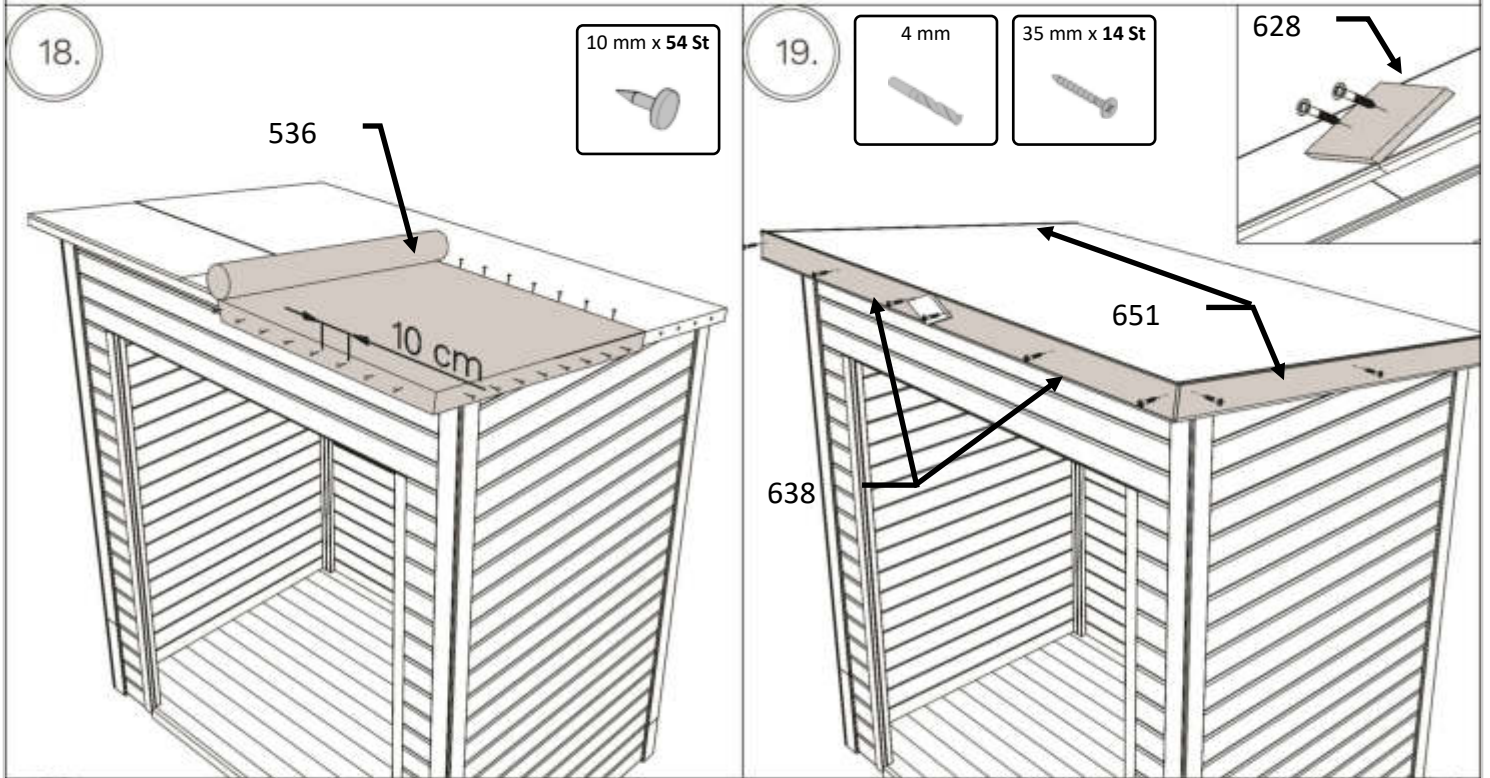

PRP4x6(NF/GR/WH)

21.

1531

Step 1.

Step 2.

21.1

Step 3.

21.2

Step 4.

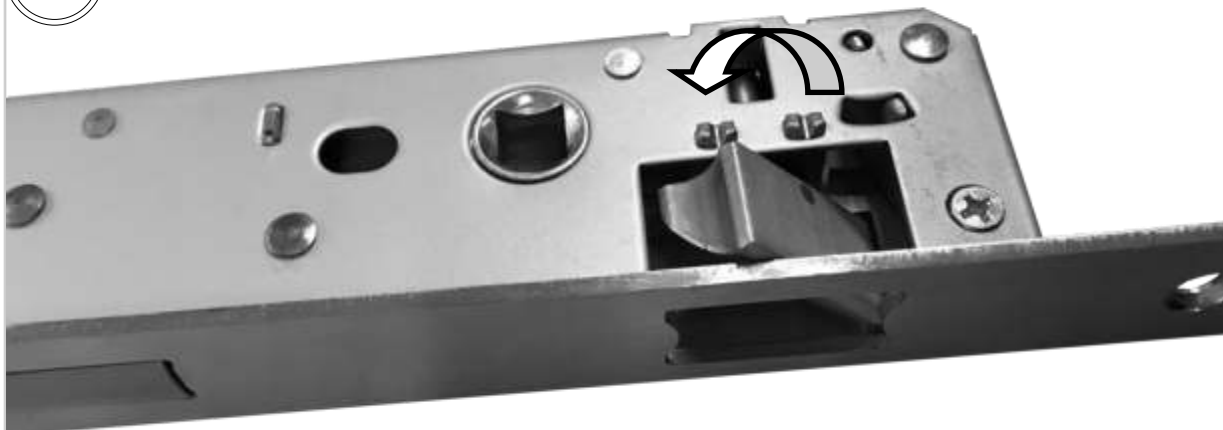
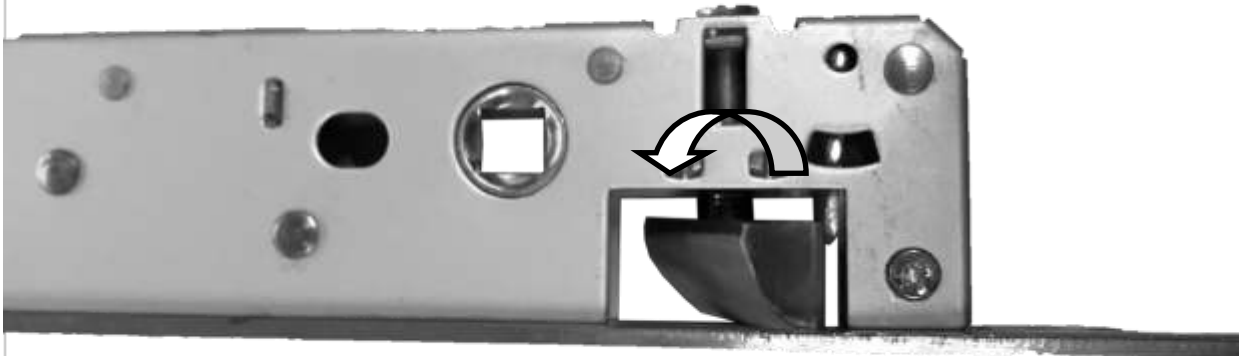
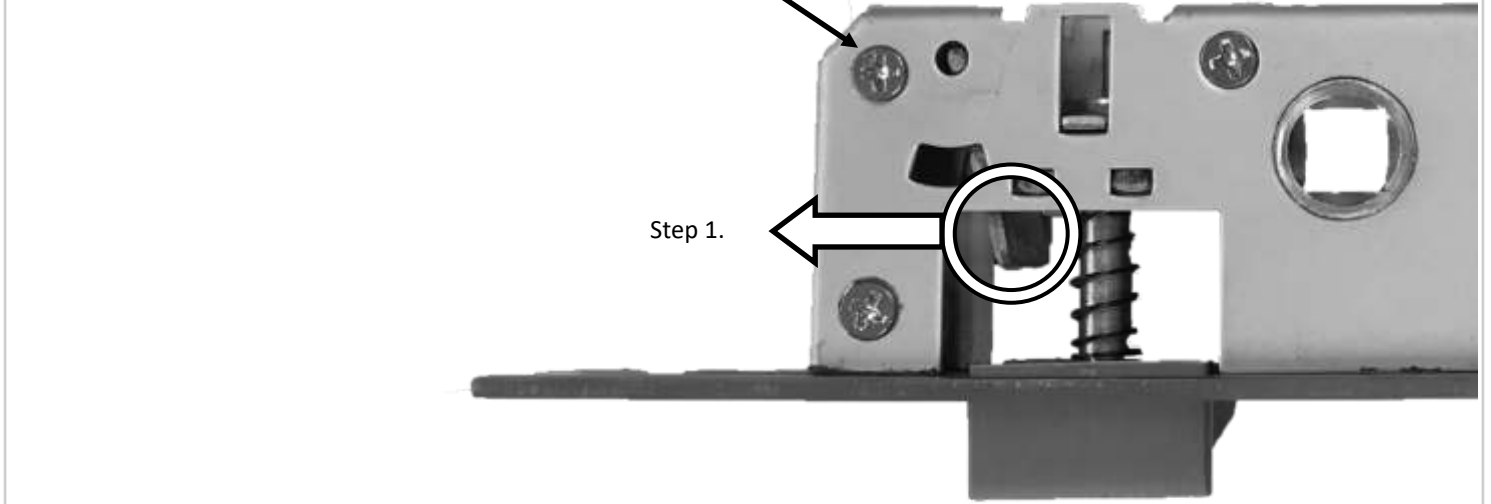

PRP4x6(NF/GR/WH)

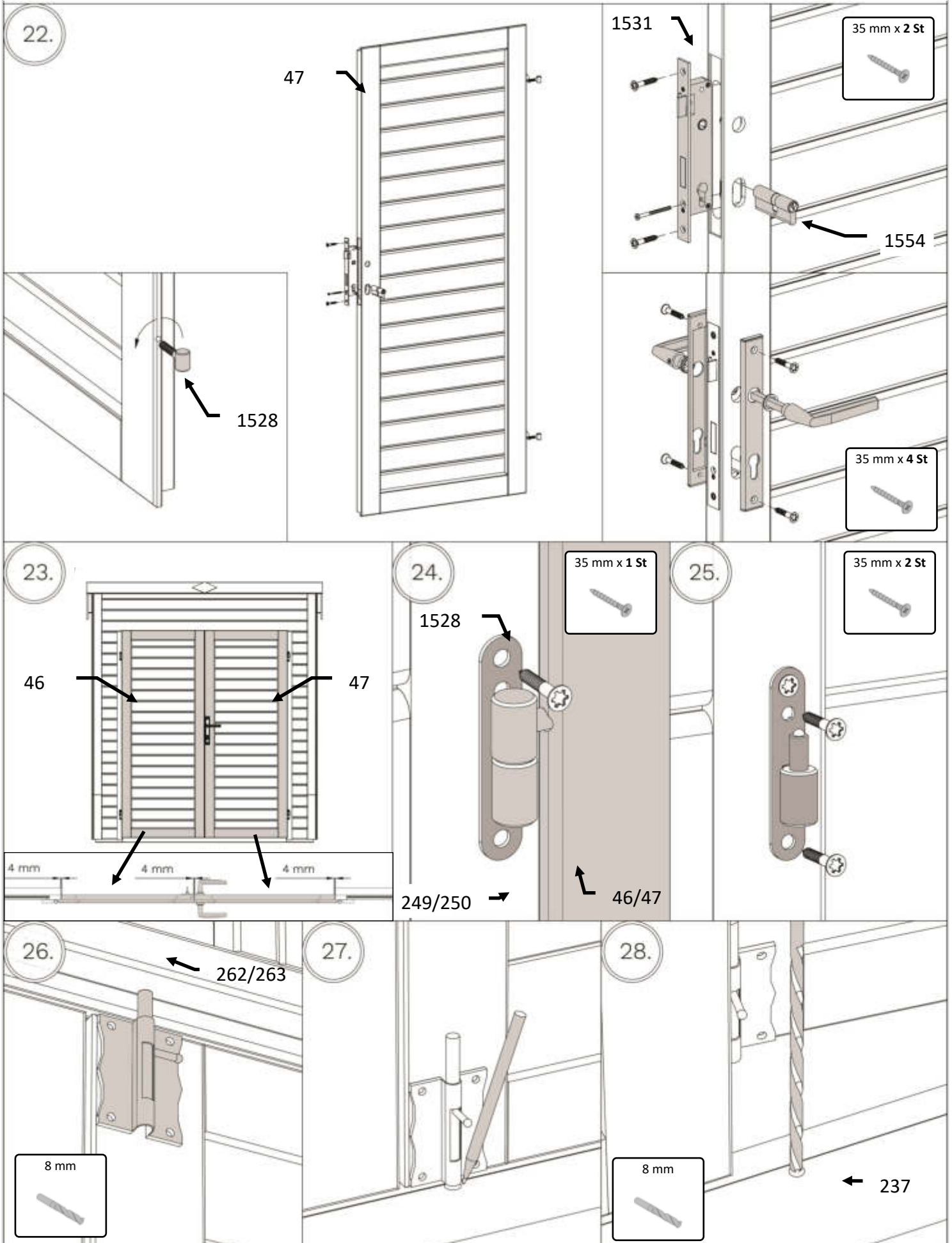

PRP4x6(NF/GR/WH)

29.

589

