

WPC GARDEN SHEDS INSTALLATION MANUAL FOR XF-H008

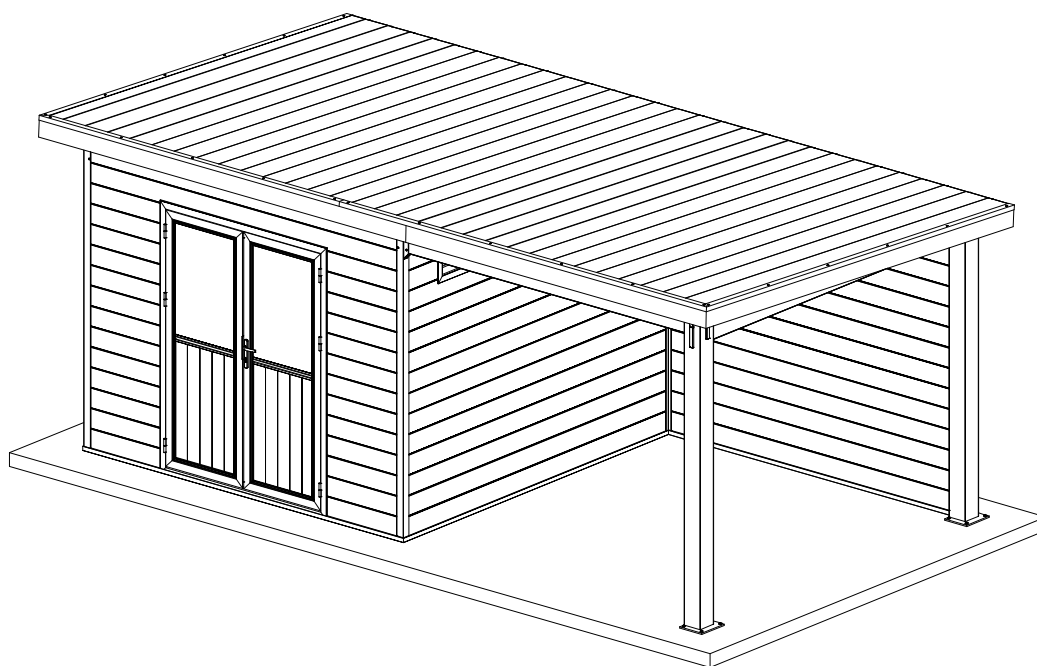

APPEARANCE & SIZE :

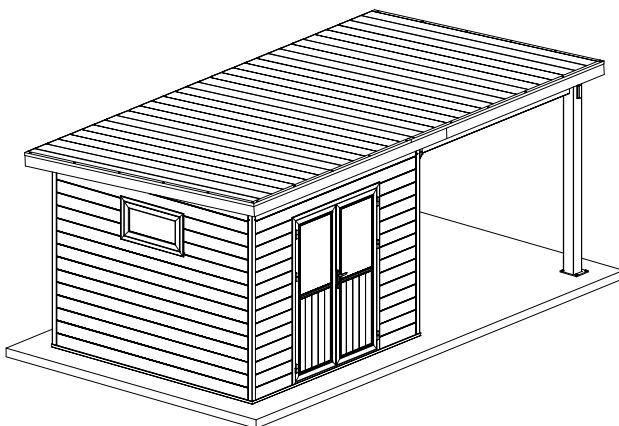
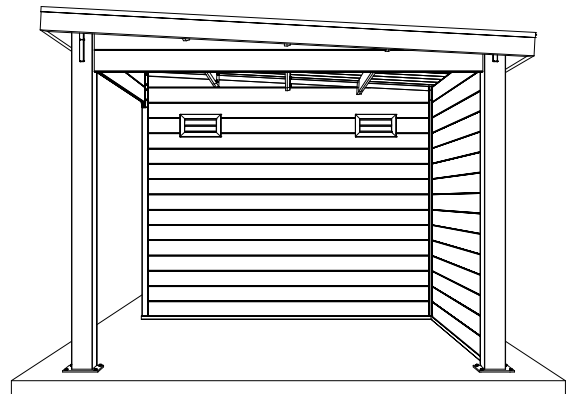
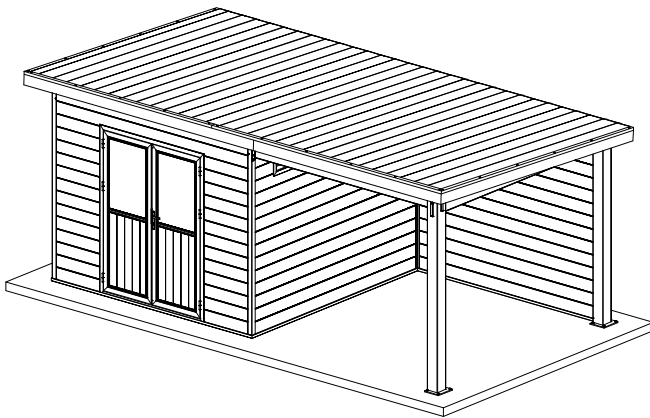
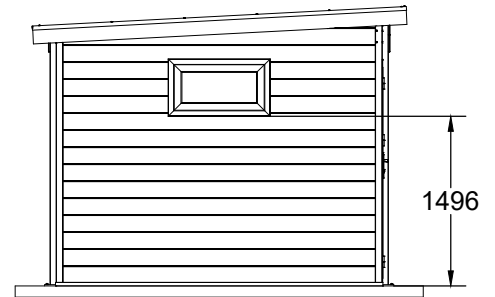
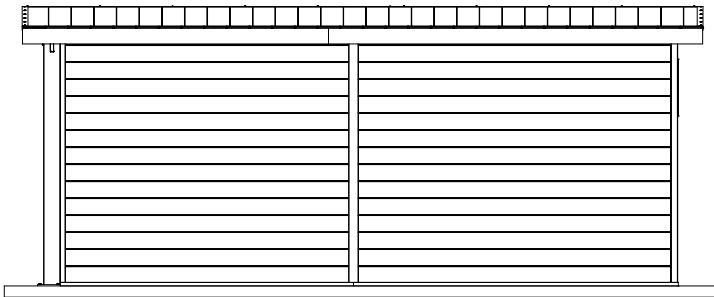
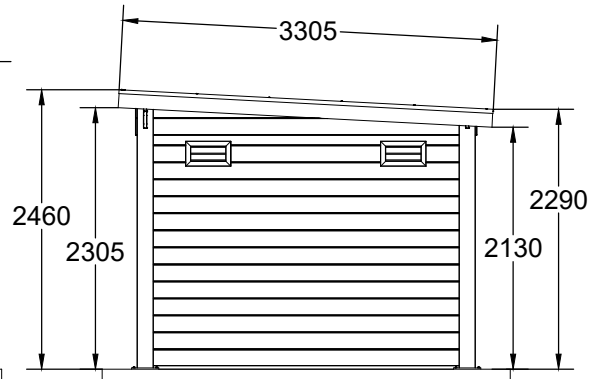
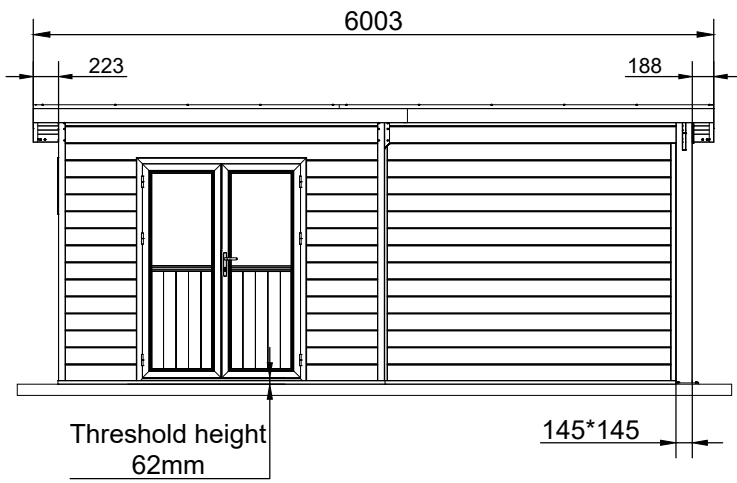

Installation Requirement :



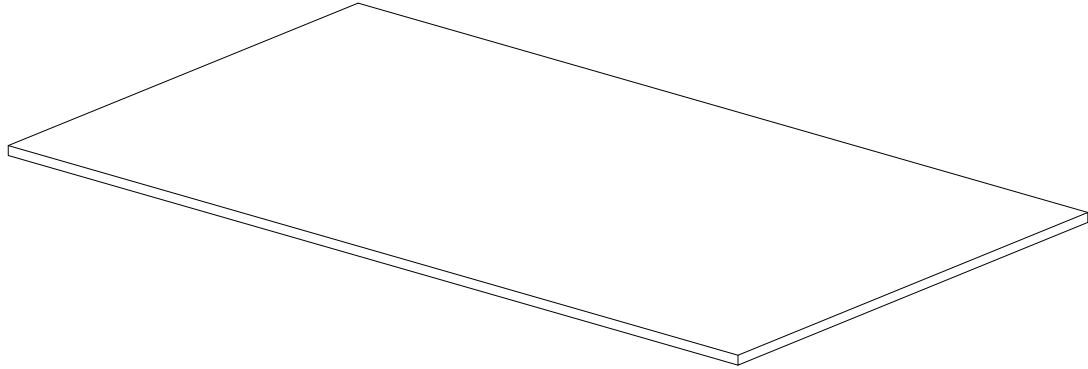

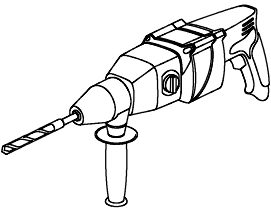
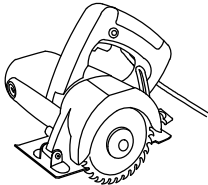
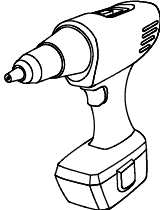
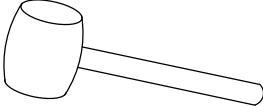
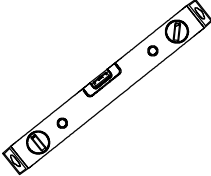
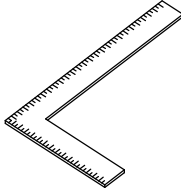
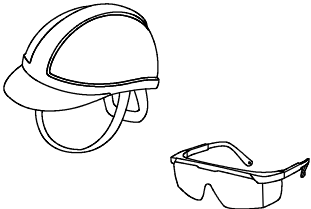
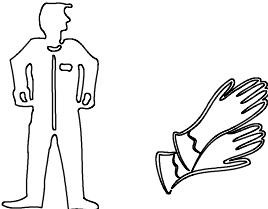
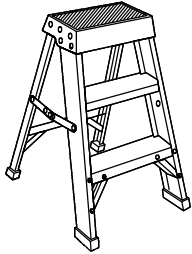

When do the assembling of a garden shed, a hard and flat ground without slope is needed. Please also make sure that the installation site has a good ventilation and drainage condition.



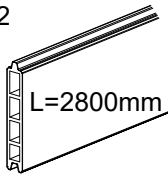
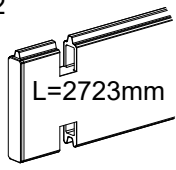
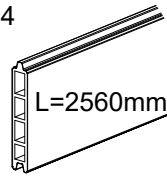
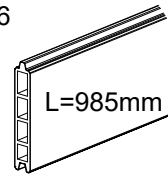
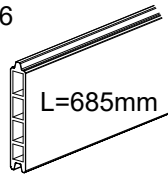
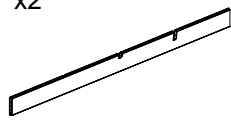
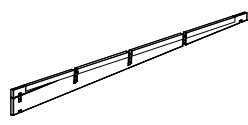
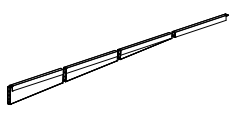
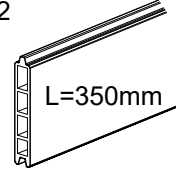
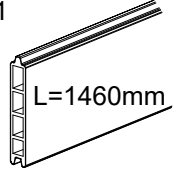
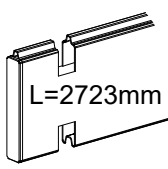
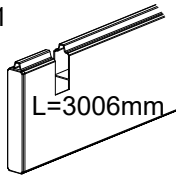
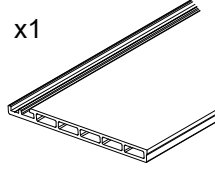
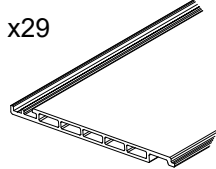
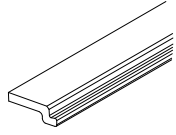
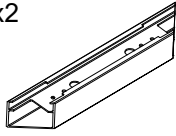
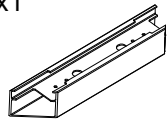
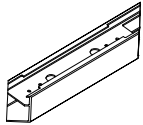
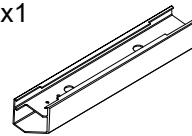



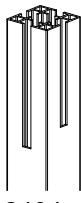
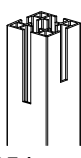
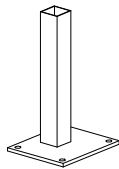
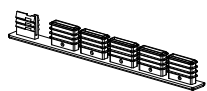
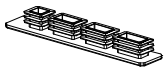
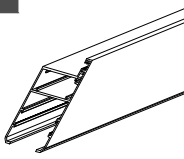
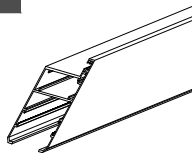
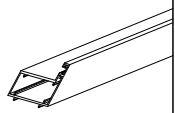
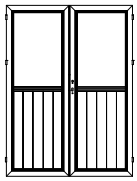

When dealing with any type of construction project, it is necessary to wear appropriate safety equipment to avoid any risk of injuries. We recommend but not only limited to the following safety equipment when handling, cutting, and installation : gloves, eye protector, respirator, long sleeves and pants.

<p>Impact electric drill</p> 	<p>Cutting machine</p> 	<p>Electric screwdriver</p> 
<p>Tape & Hammer</p> 	<p>Levelling Instrument</p> 	<p>L-square</p> 
<p>Safety helmet & Goggles</p> 	<p>Work clothes, gloves & protective shoes</p> 	<p>Ladder</p> 

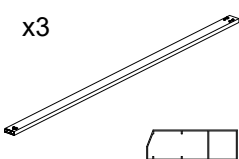
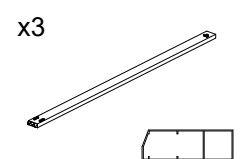
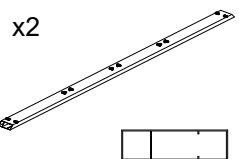
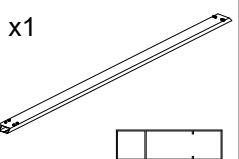
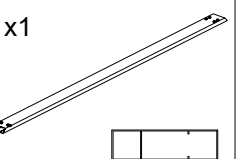
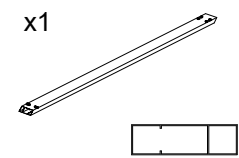
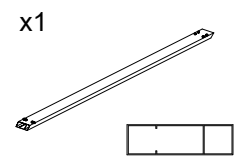
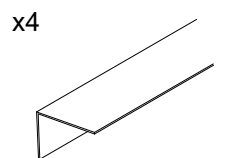
List of components

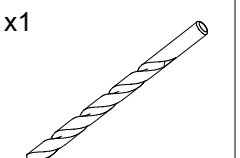
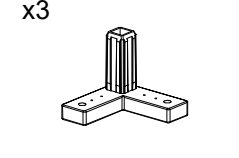
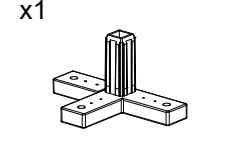
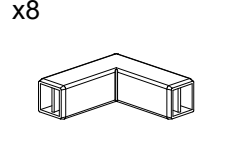
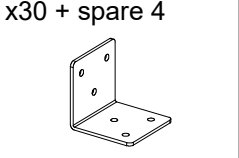
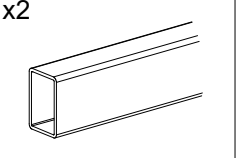
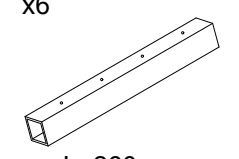
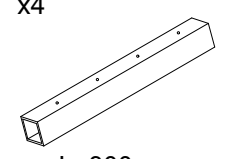
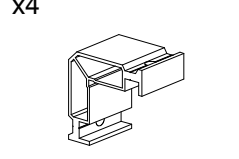
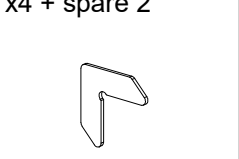
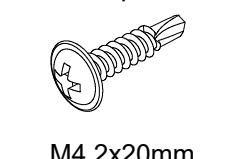
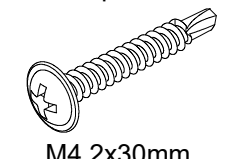
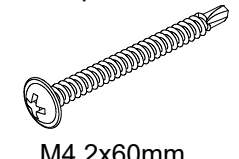
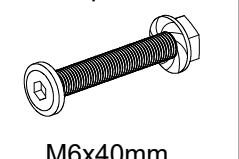
WP1 x42  L=2800mm	WP2 x2  L=2723mm	WP3 x14  L=2560mm	WP4 x6  L=985mm	WP5 x26  L=685mm
WP6 x2  L=2800mm	WP7 x1  L=3306mm	WP8 x2  L=2800mm	WP9 x2  L=350mm	WP10 x1  L=1460mm
AP1 x1  L=2723mm	AP2 x1  L=3006mm	TP1 x1  L=3300mm	TP2 x29  L=3300mm	TP3 x1  L=3300mm
BF1 x2  L=2885mm	BF2 x1  L=2862.5mm	BF3 x1  L=2862.5mm	BF4 x1  L=2585mm	
MF1 x1 	MF2 x1 	MF3 x1 	MF4 x1 	MF5 x1 
PO1 x1  L=2404mm	PO2 x1  L=2254mm	ST1 x2 	Spare parts x2 	Spare parts x3 
DF1 x2  L=1965mm	DF2 x1  L=1502mm	DF3 x1  L=1502mm	DP-1 x1 	

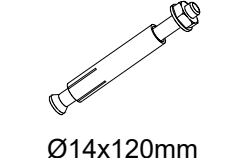
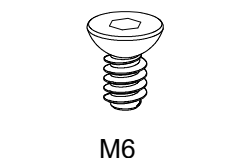
List of components

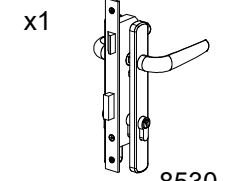
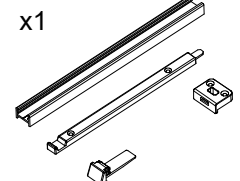
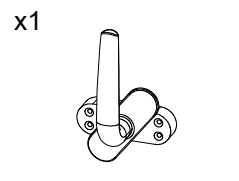
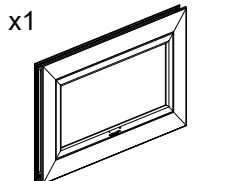
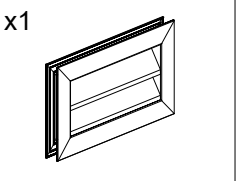
TF1 x3  L=3300mm	TF2 x3  L=2620mm	TF3 x2  L=3300mm	TF4 x1  L=3300mm	TF5 x1  L=3300mm
TF6 x1  L=2740mm	TF7 x1  L=2740mm	TF8 x4 	TOOL1 x1  Ø2.8	TOOL2 x1  Ø7
CL-1 x3 	CL-2 x1 	CL-3 x8 	CL-4 x30 + spare 4 	CL-5 x2  L=780mm
CL-6 x6  L=260mm	CL-7 x4  L=300mm	CL-8 x4 	CL-9 x4 + spare 2 	
SC-1 x535 + spare 165  M4.2x20mm	SC-2 x24 + spare 6  M4.2x30mm	SC-3 x7 + spare 3  M4.2x60mm	SC-4 x32 + spare 4  M6x40mm	SC-5 x10 + spare 2  Ø8x80mm
SC-6 x8 + spare 1  Ø14x120mm	SC-7 x8 + spare 2  M6	SC-8 x4 + spare 2  M4.2x30mm	SC-9 x4 + spare 2  M4.2x25mm	
SU-1 x1  8530	SU-2 x1 	SU-3 x1 	WD1 x1 	WD2 x1 

STEP 1 :

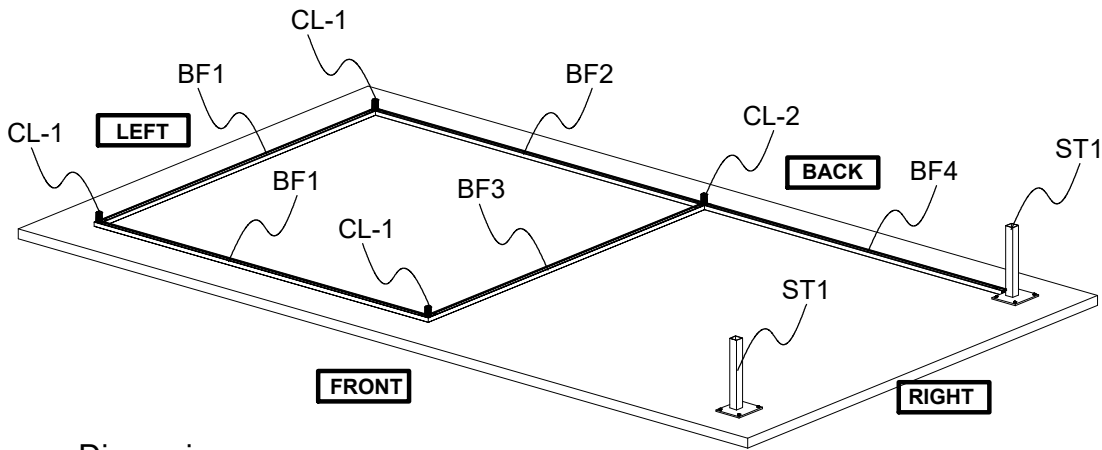
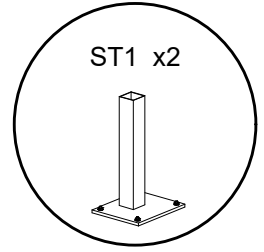
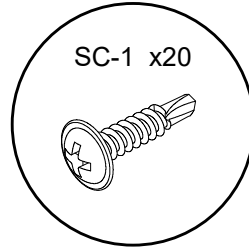
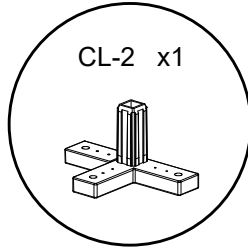
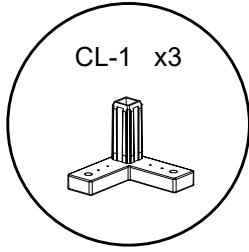
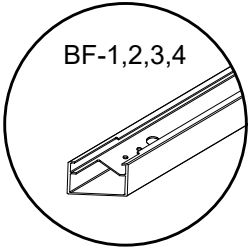

Dimension:

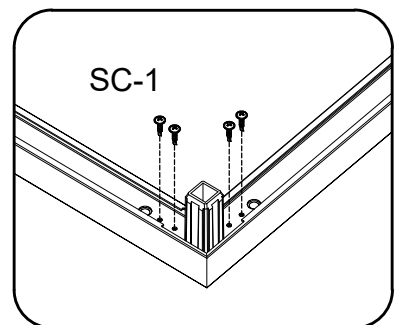
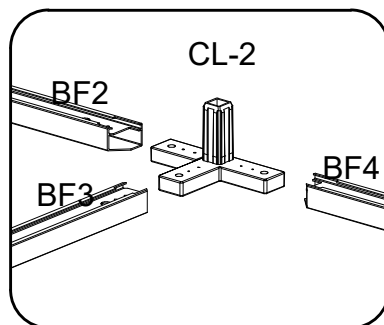
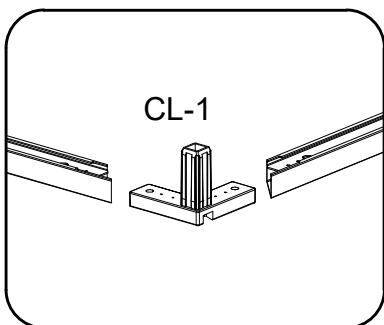
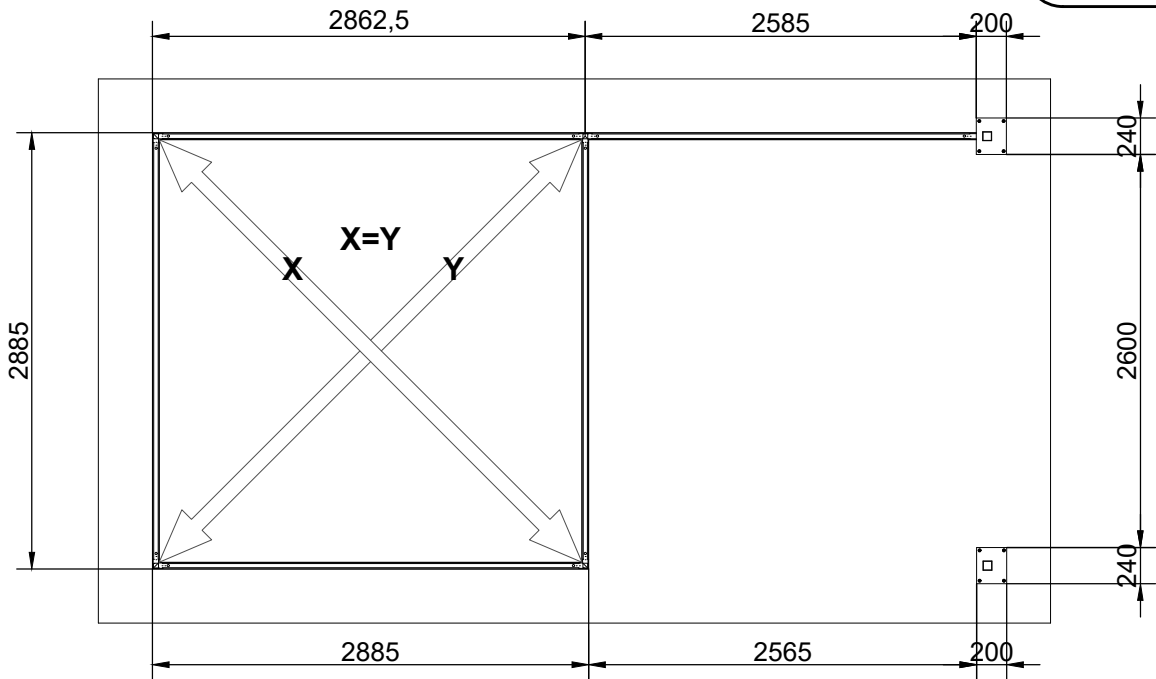

STEP 2 : Expansion screws

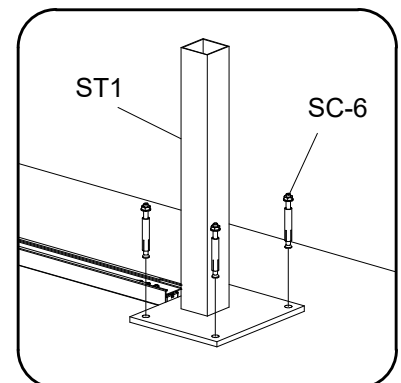
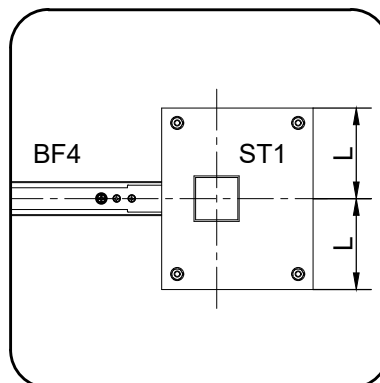
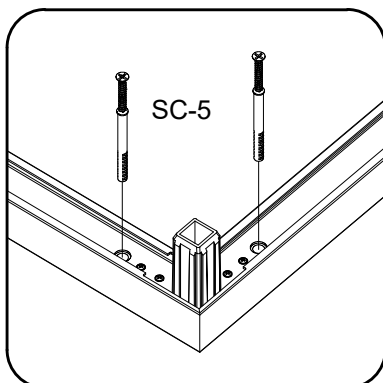
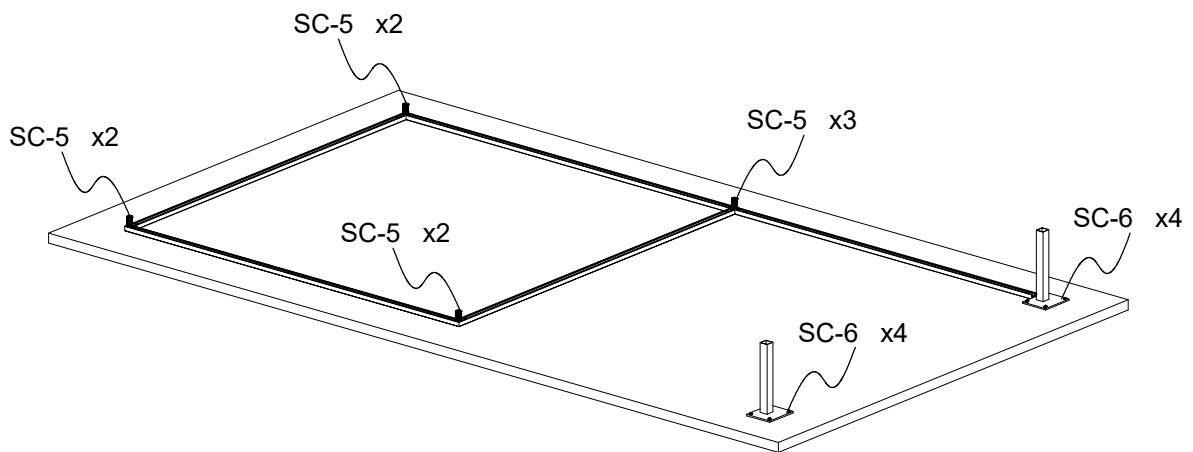
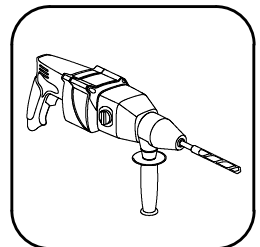
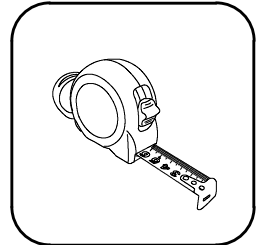
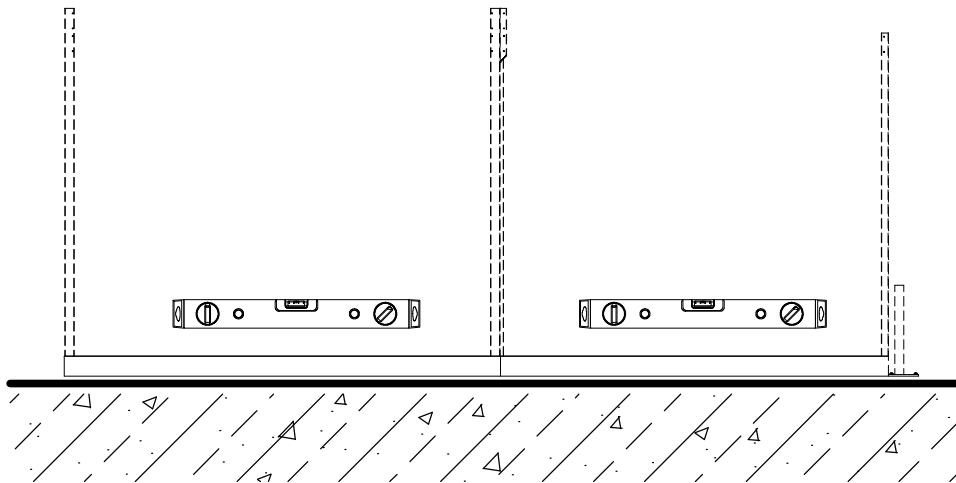
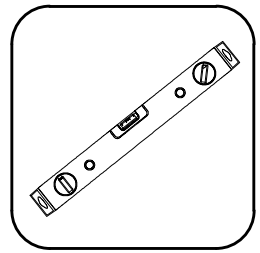
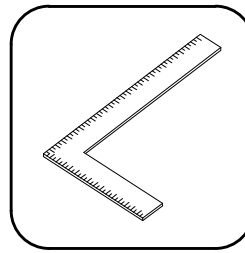
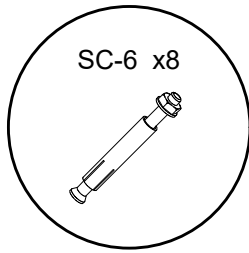
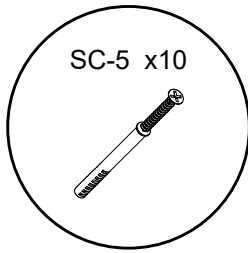

STEP 3 :

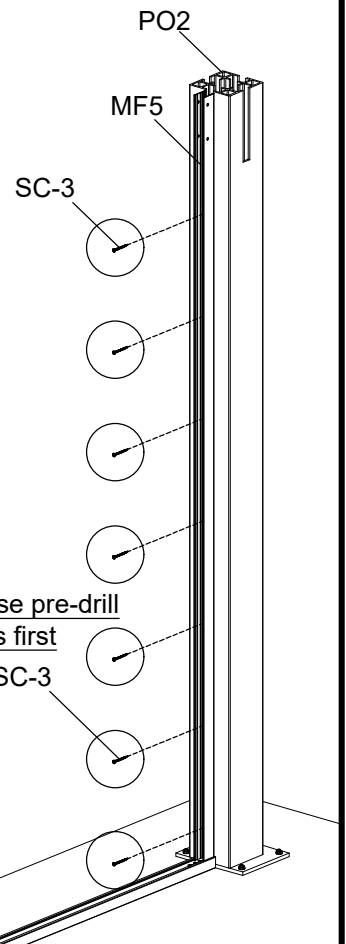
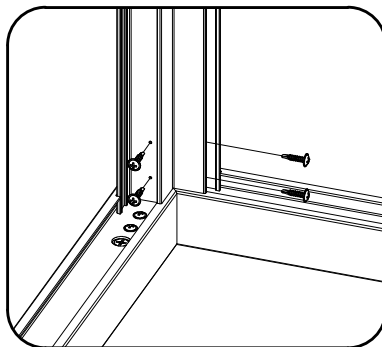
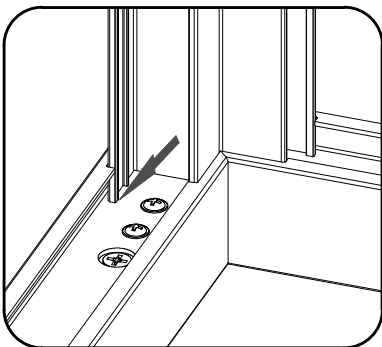
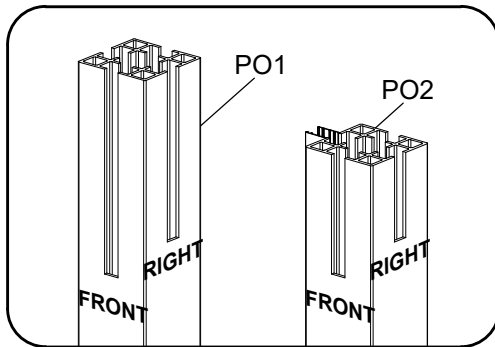
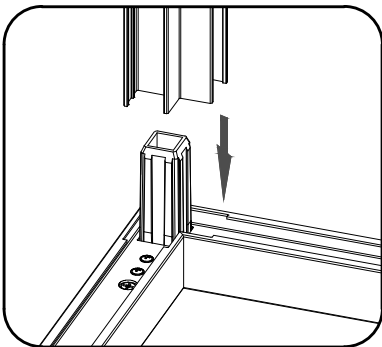
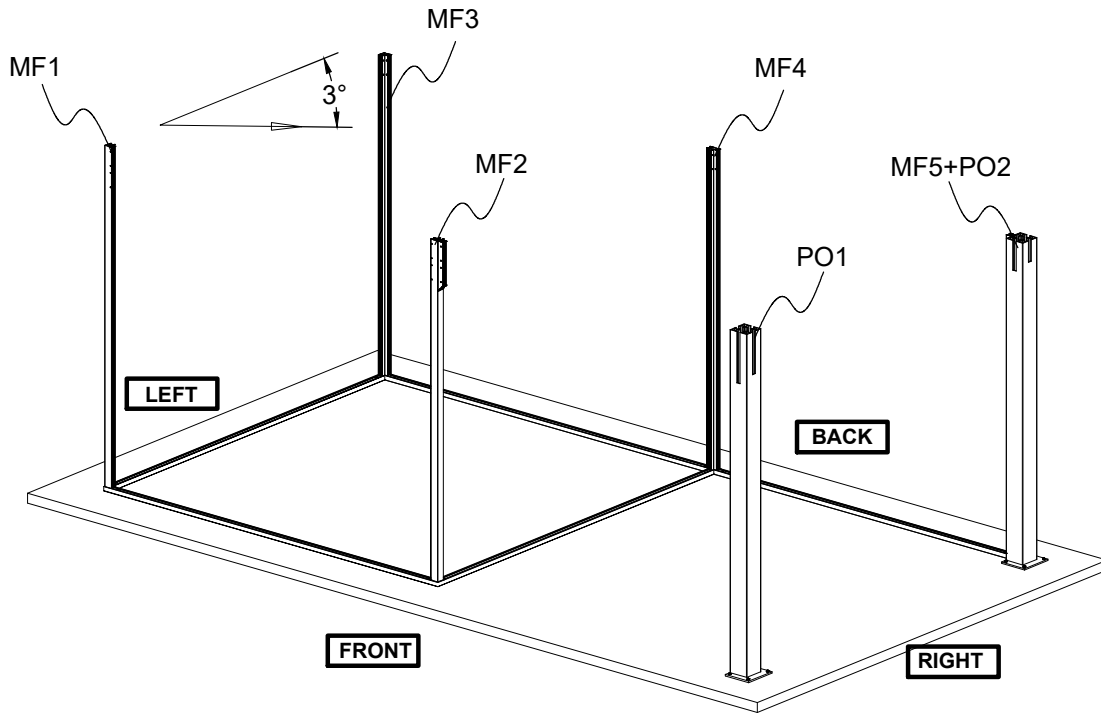
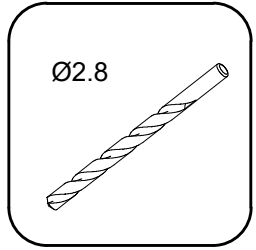
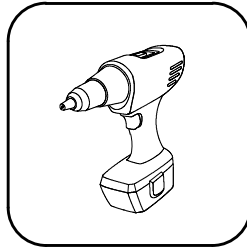
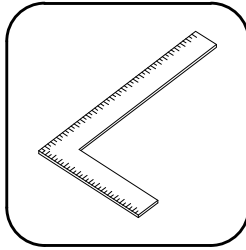
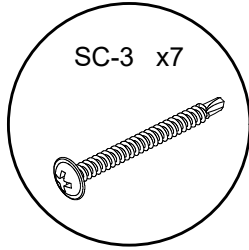
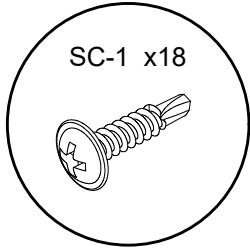

STEP 4 :

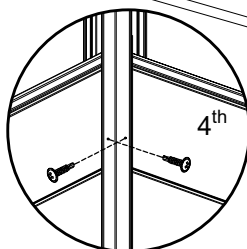
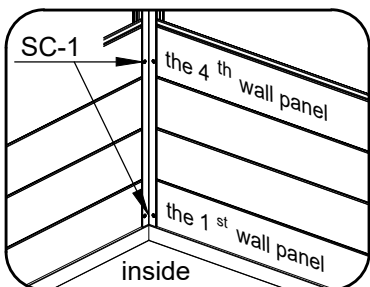
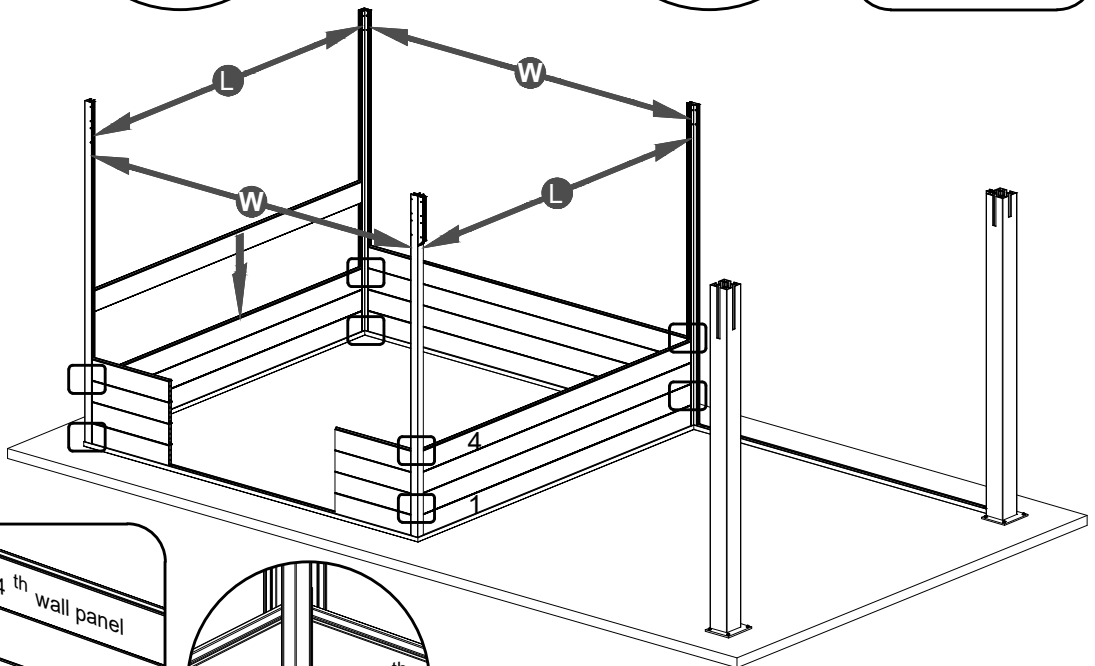
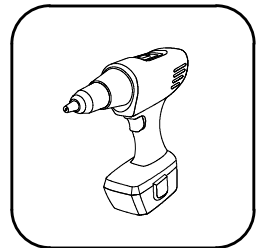
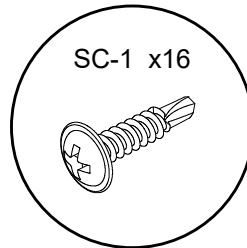
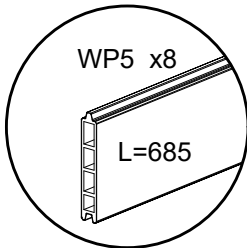
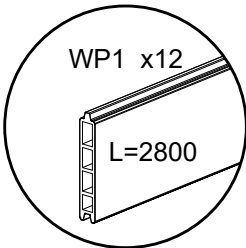
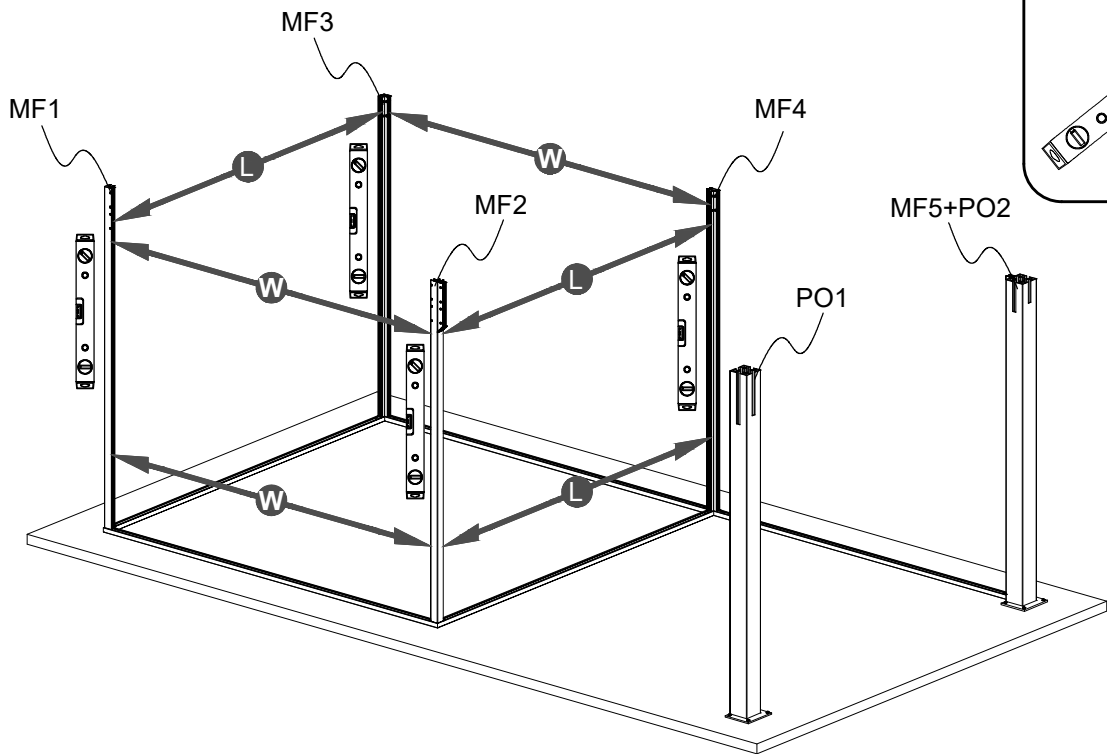

STEP 5 :

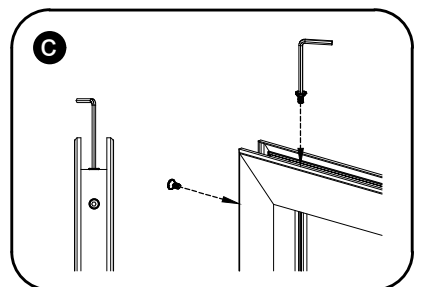
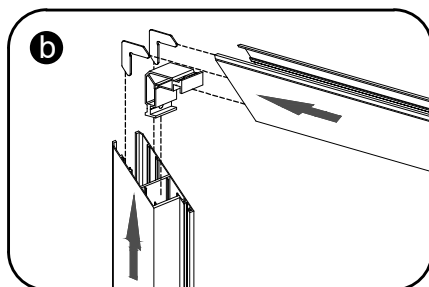
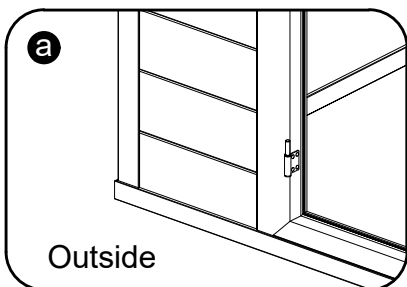
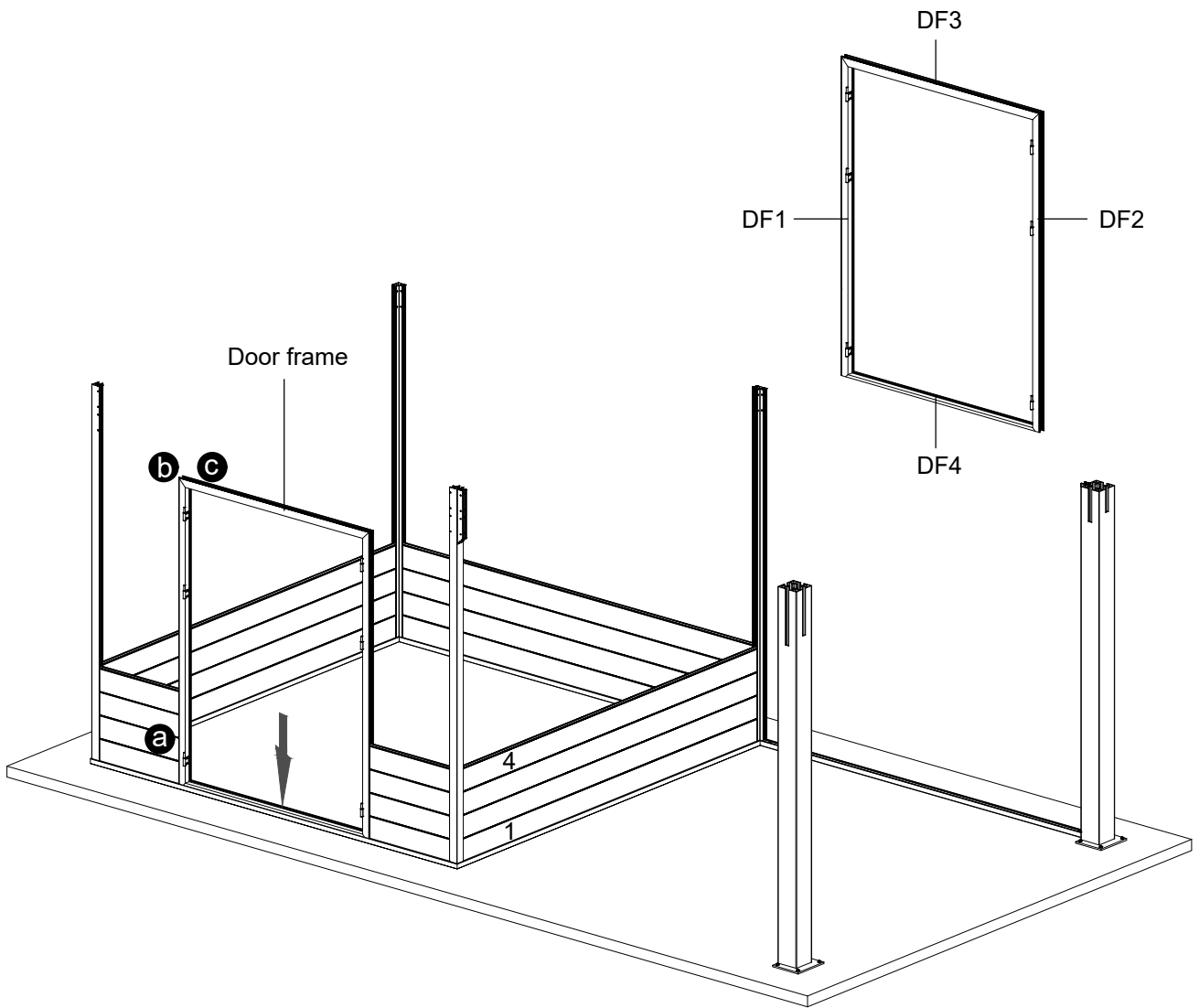
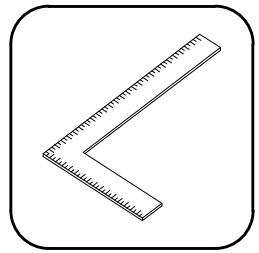
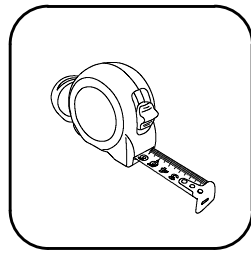
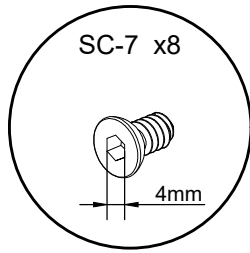
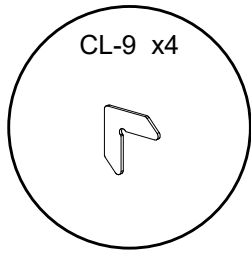
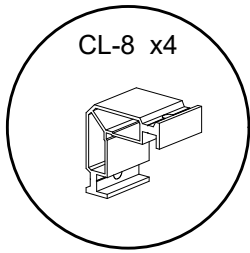

STEP 6 :

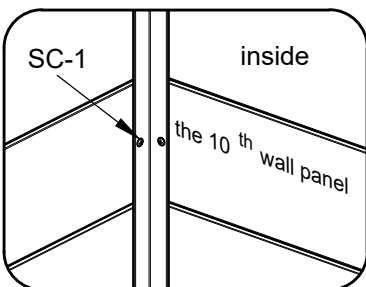
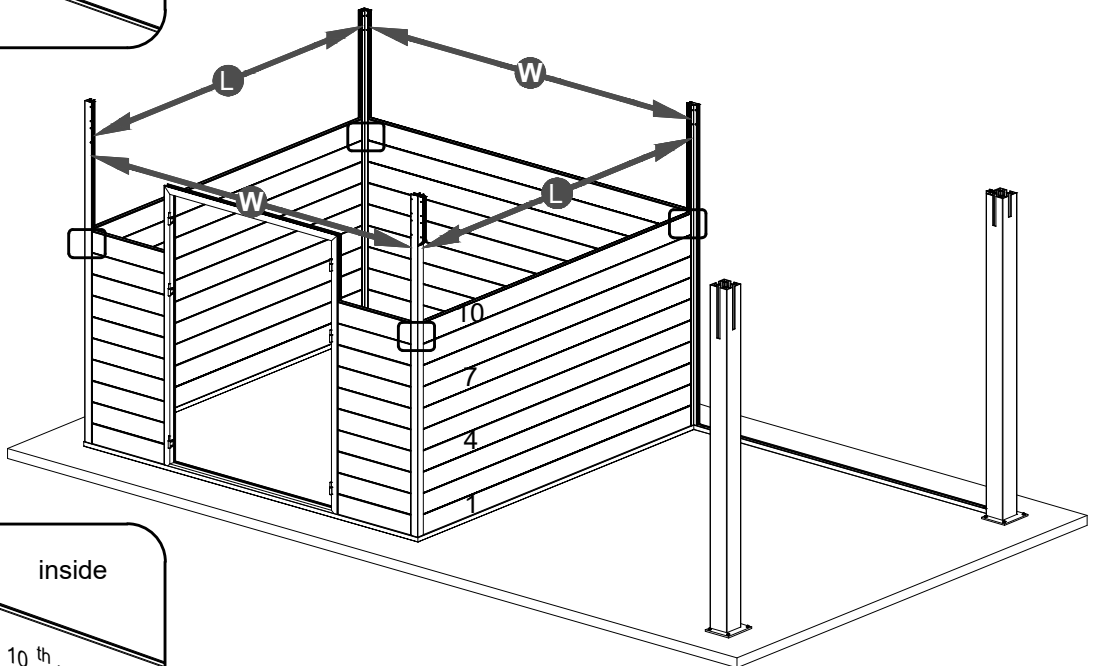
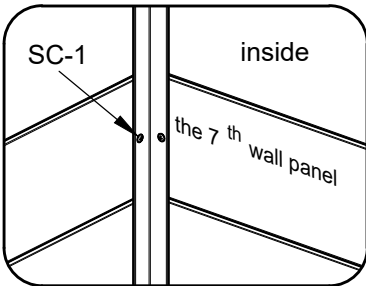
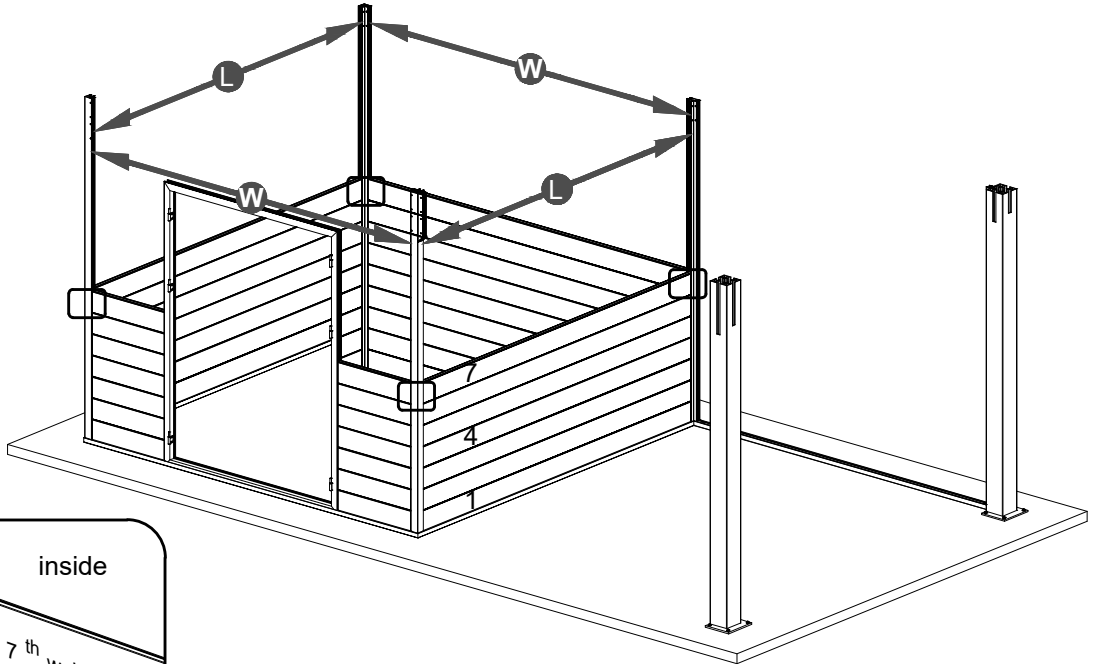
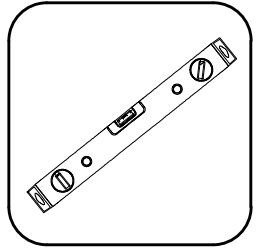
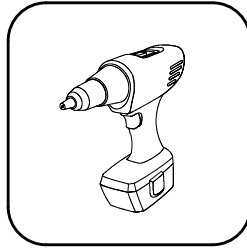
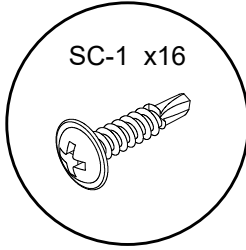
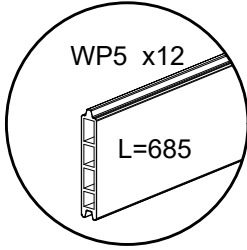
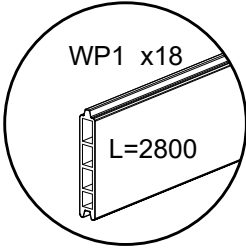

STEP 7 :

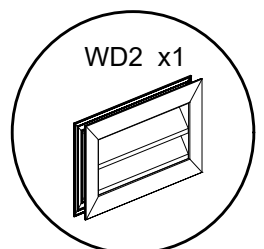
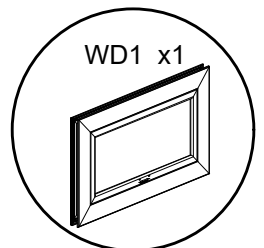
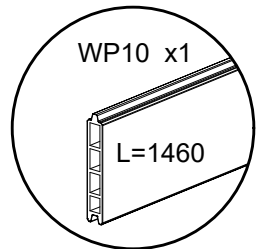
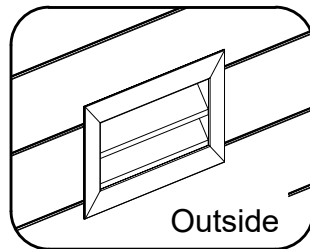
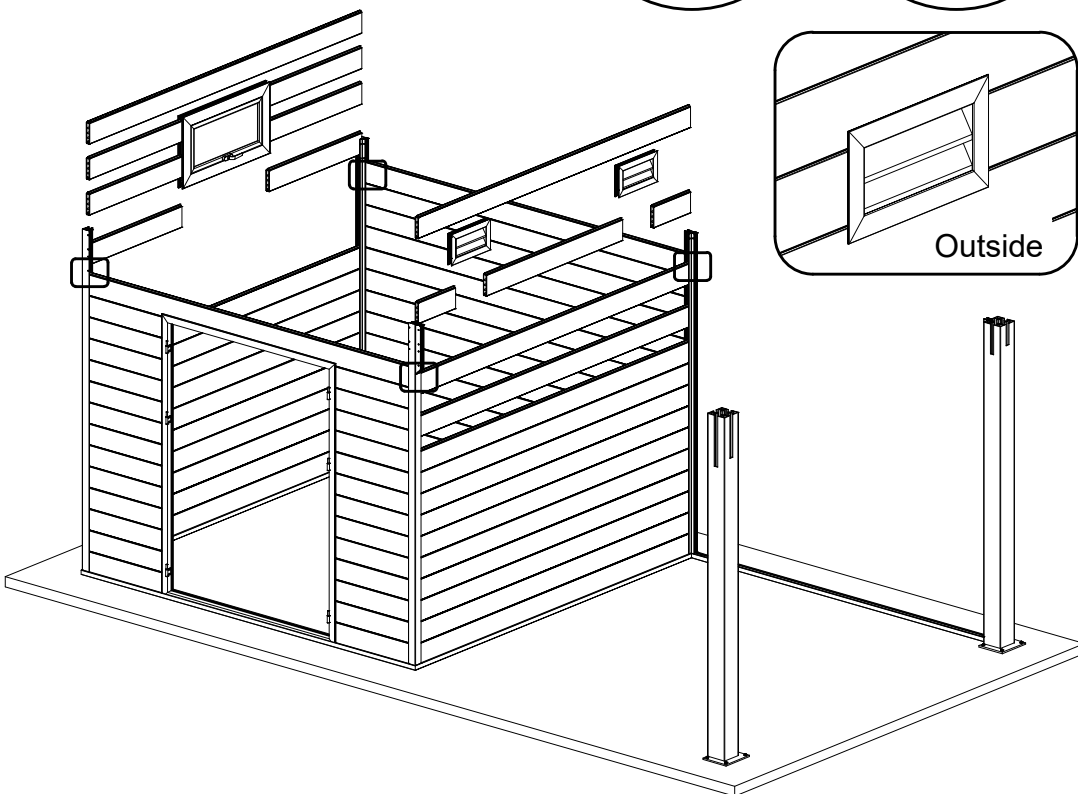
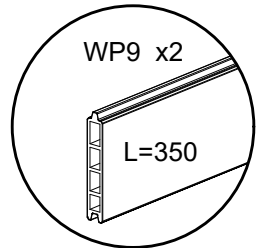
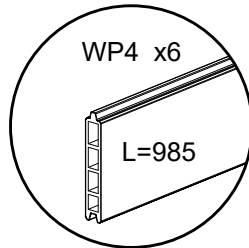
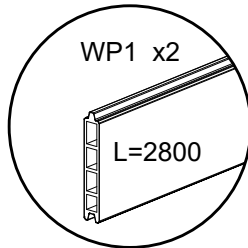
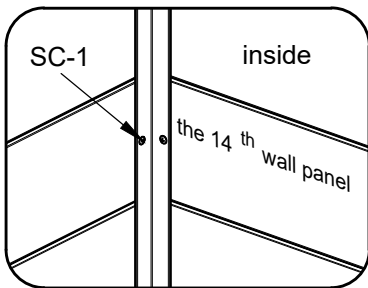
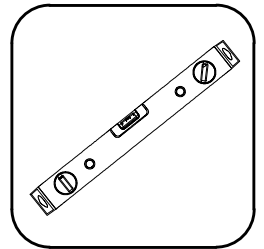
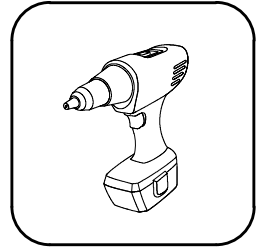
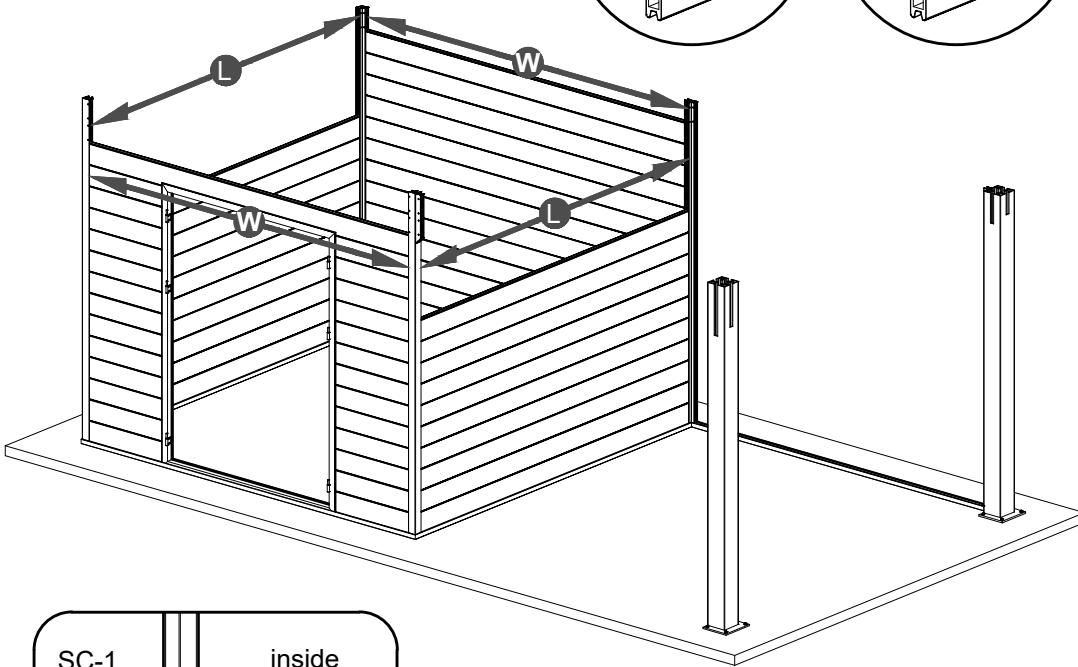
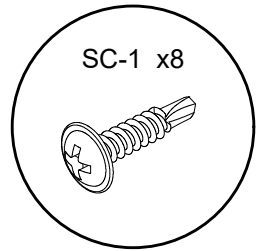
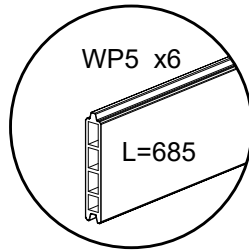
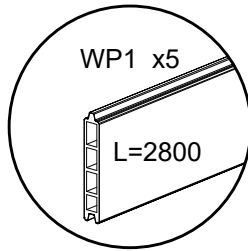

STEP 8 :

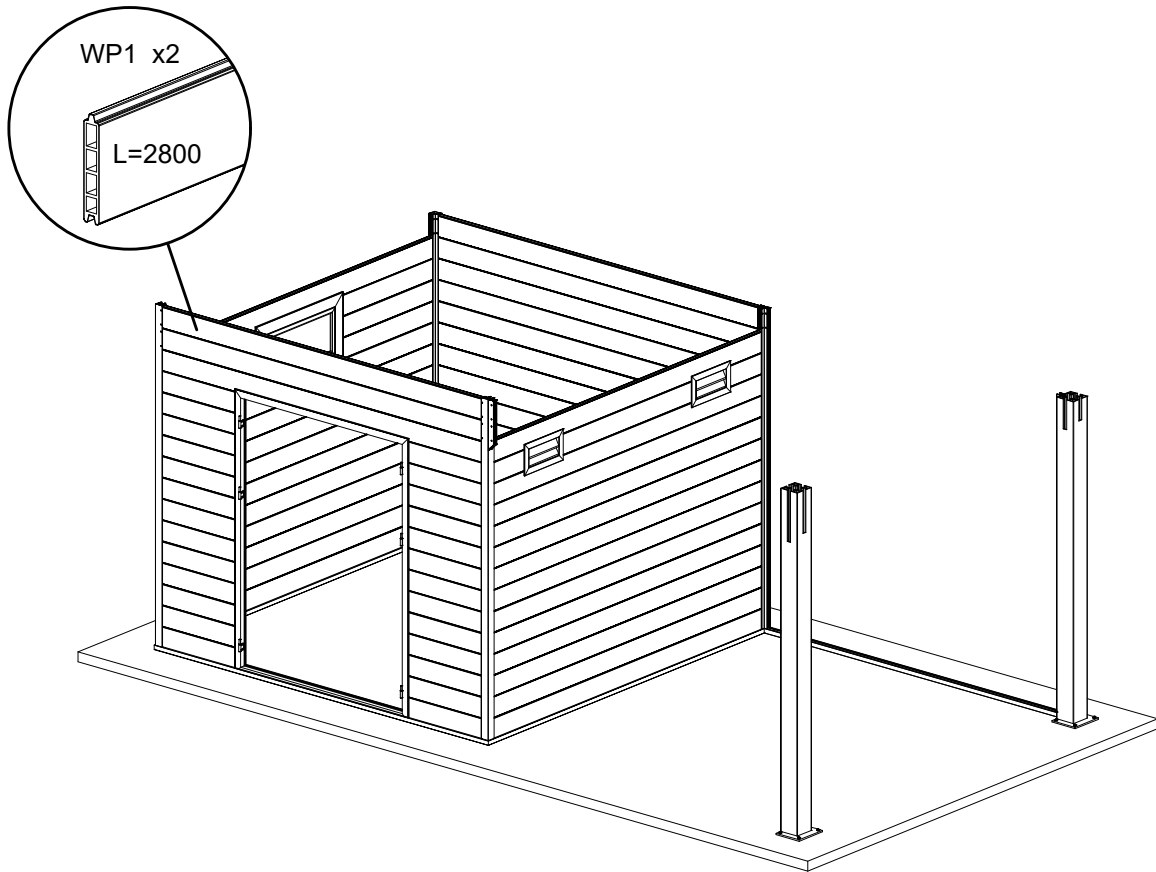

STEP 9 :

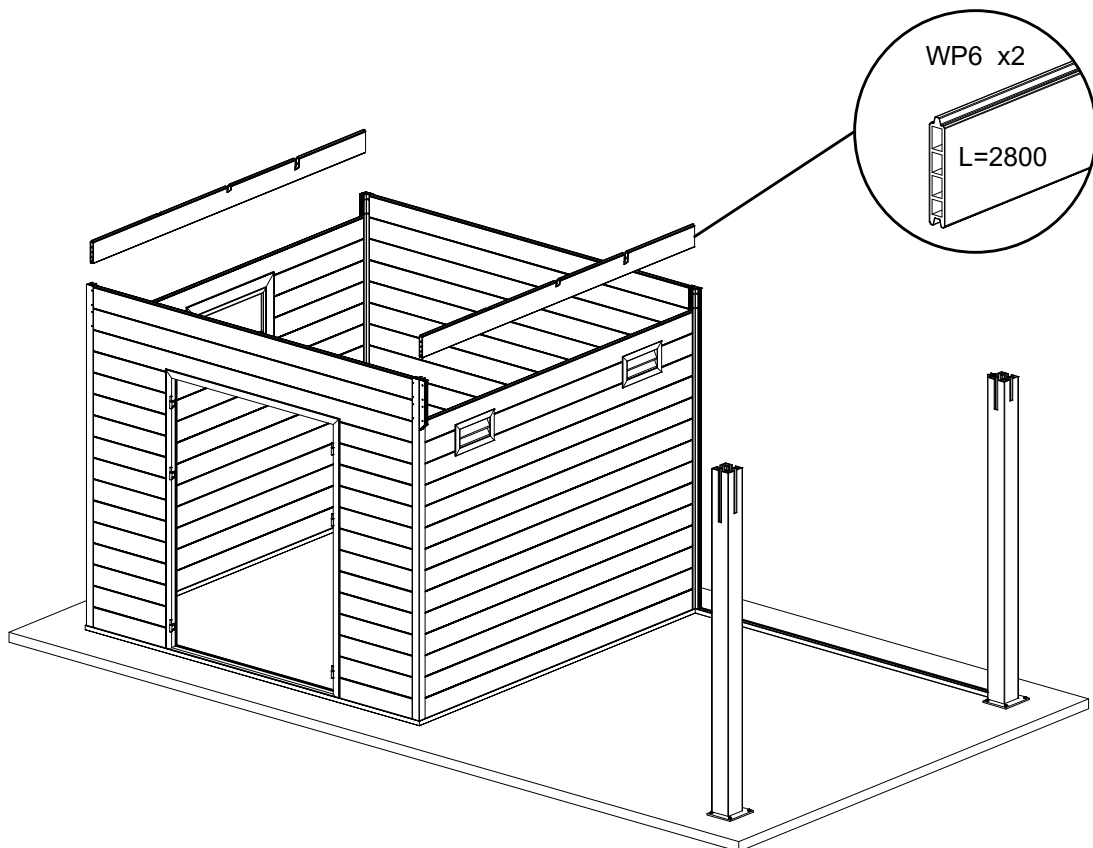

STEP 10 :

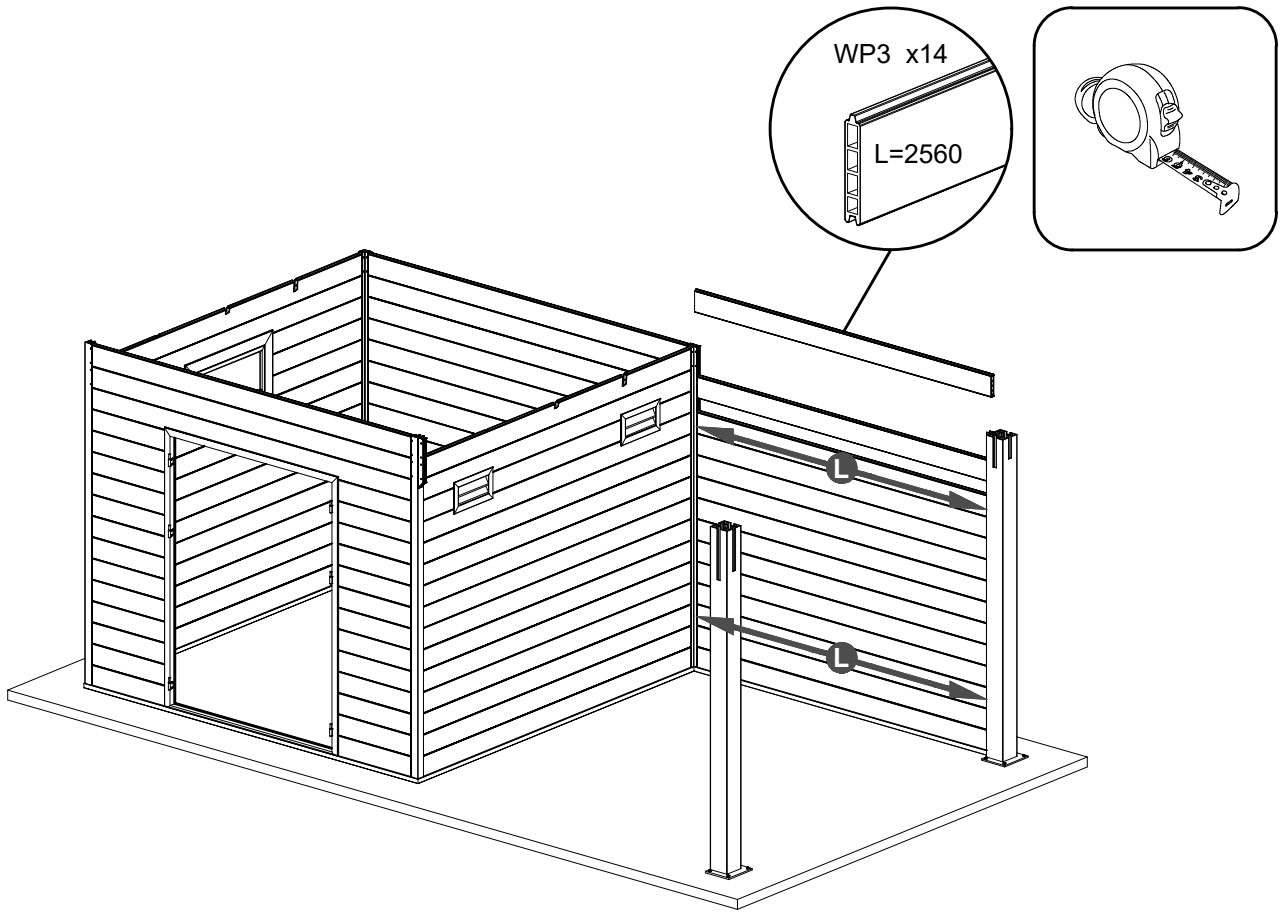

STEP 11 :

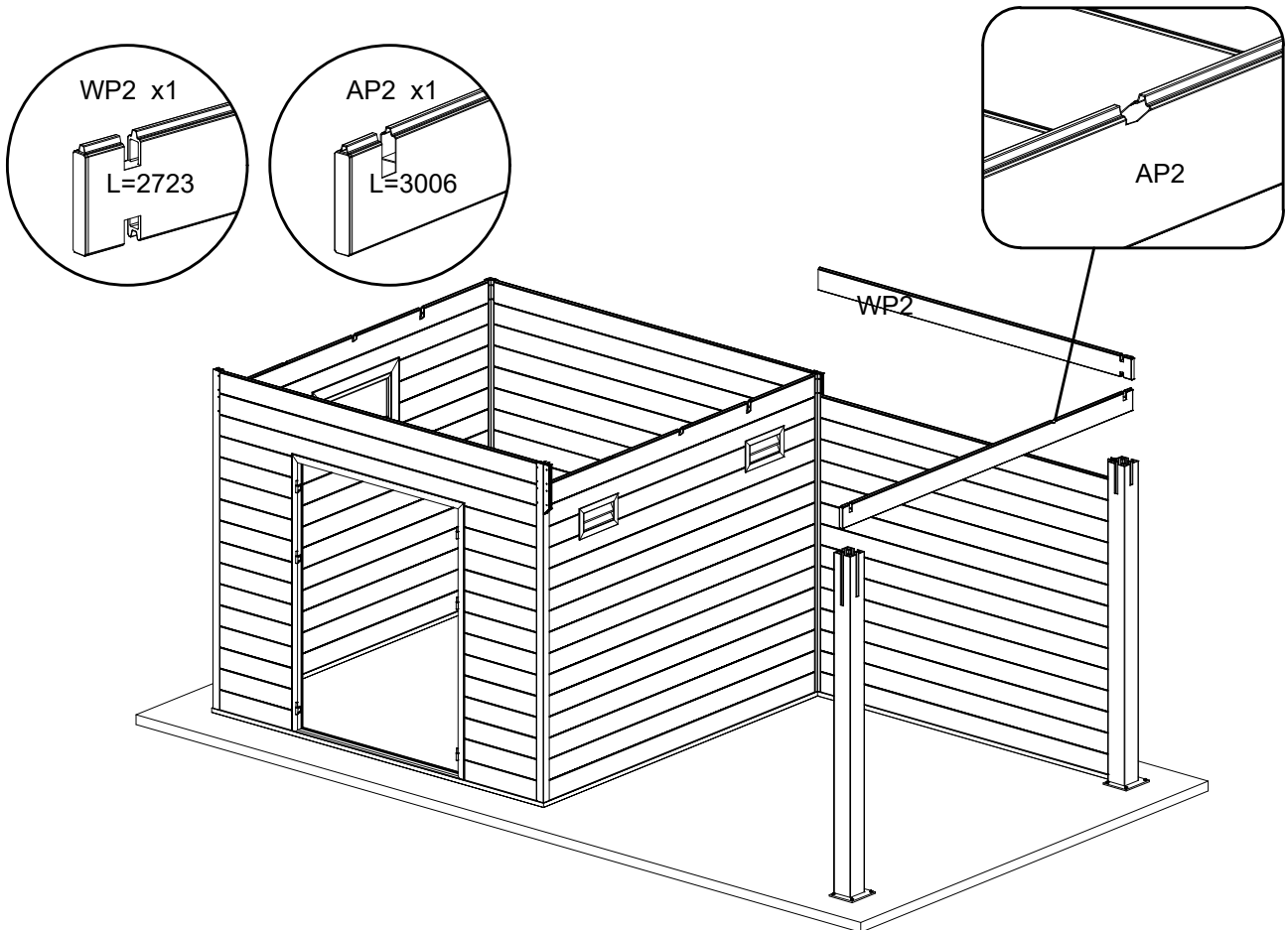

STEP 12 :

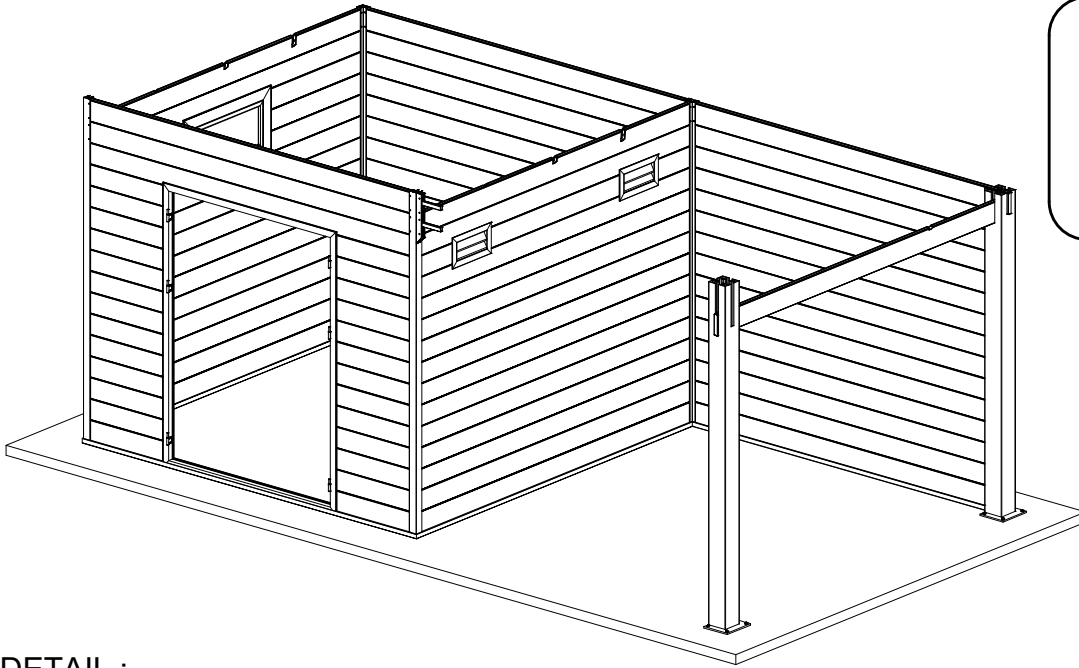
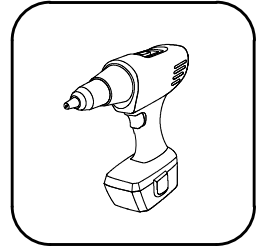
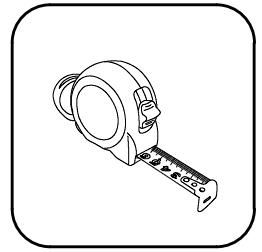
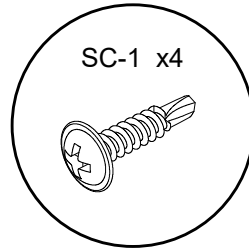
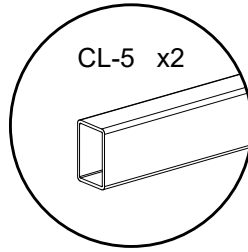

DETAIL :

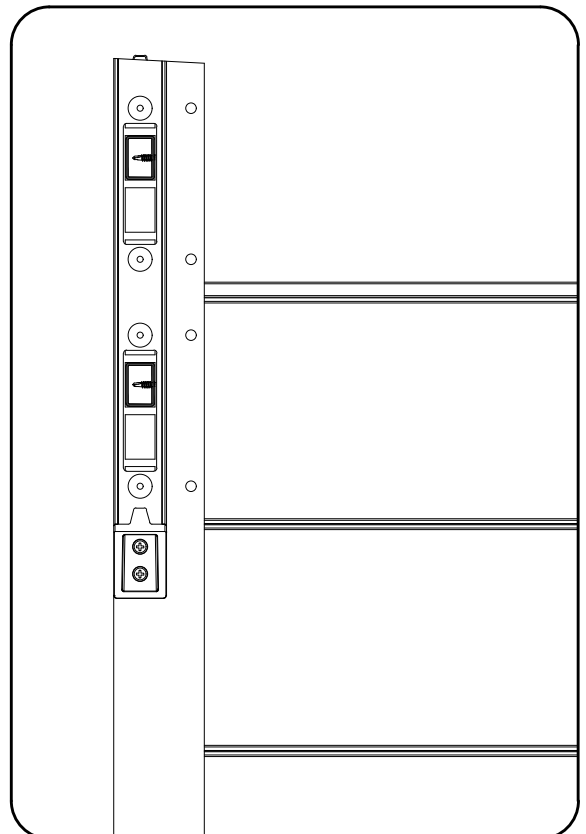
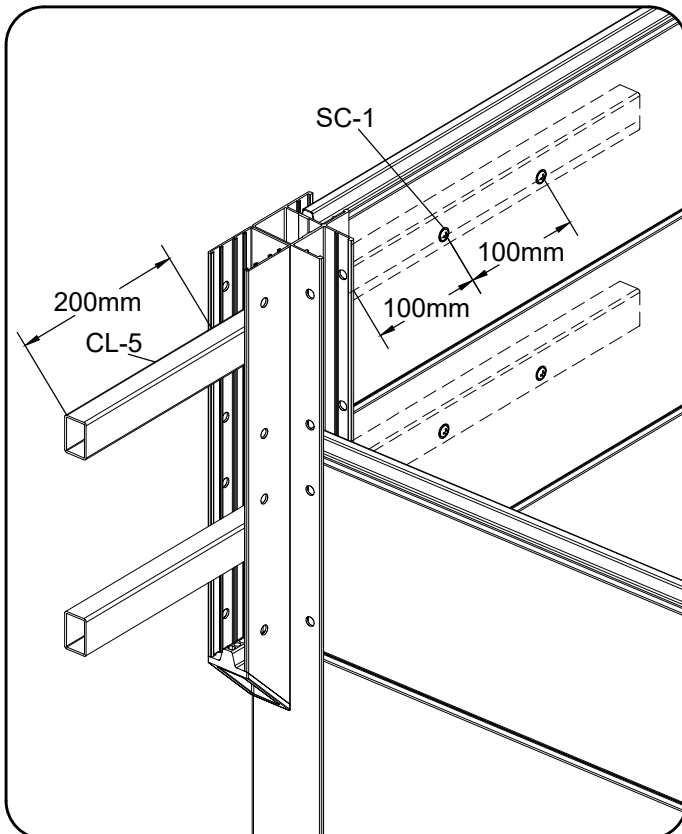

STEP 13 :

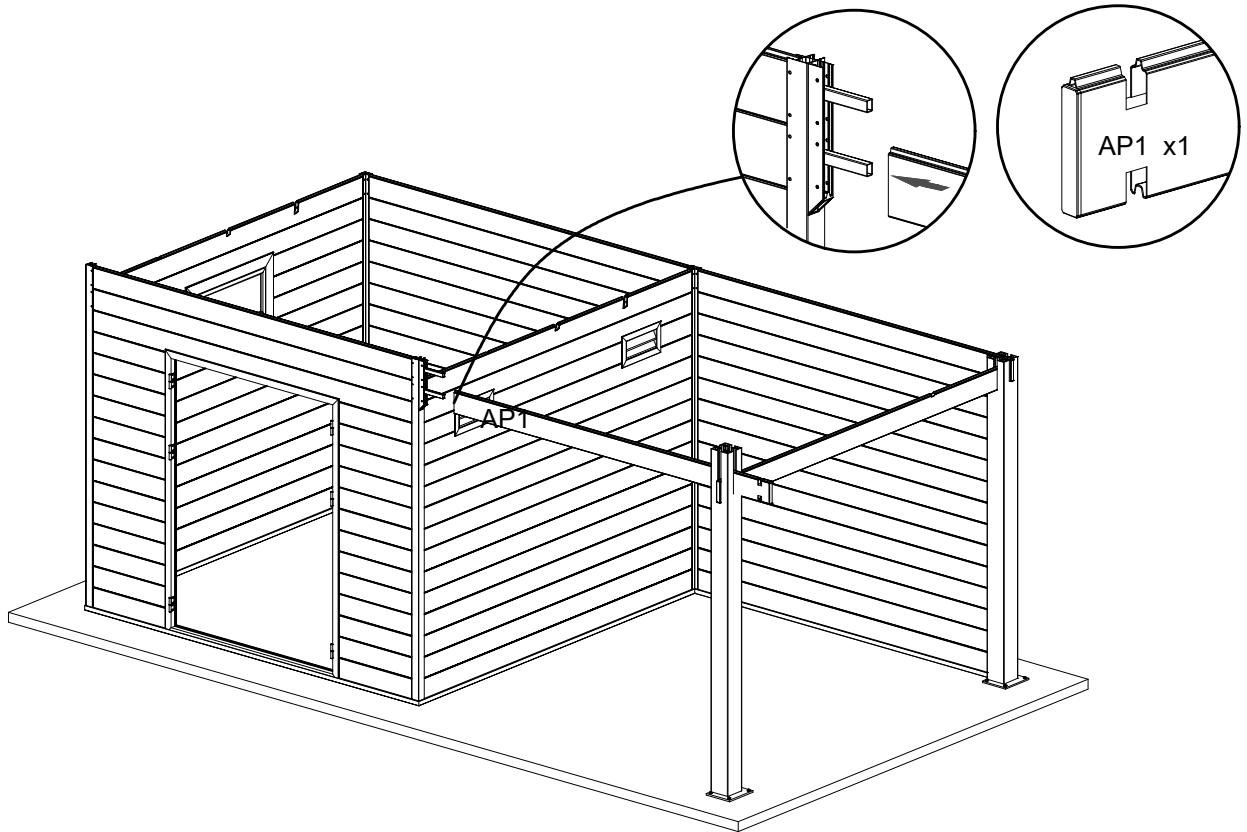

STEP 14 :

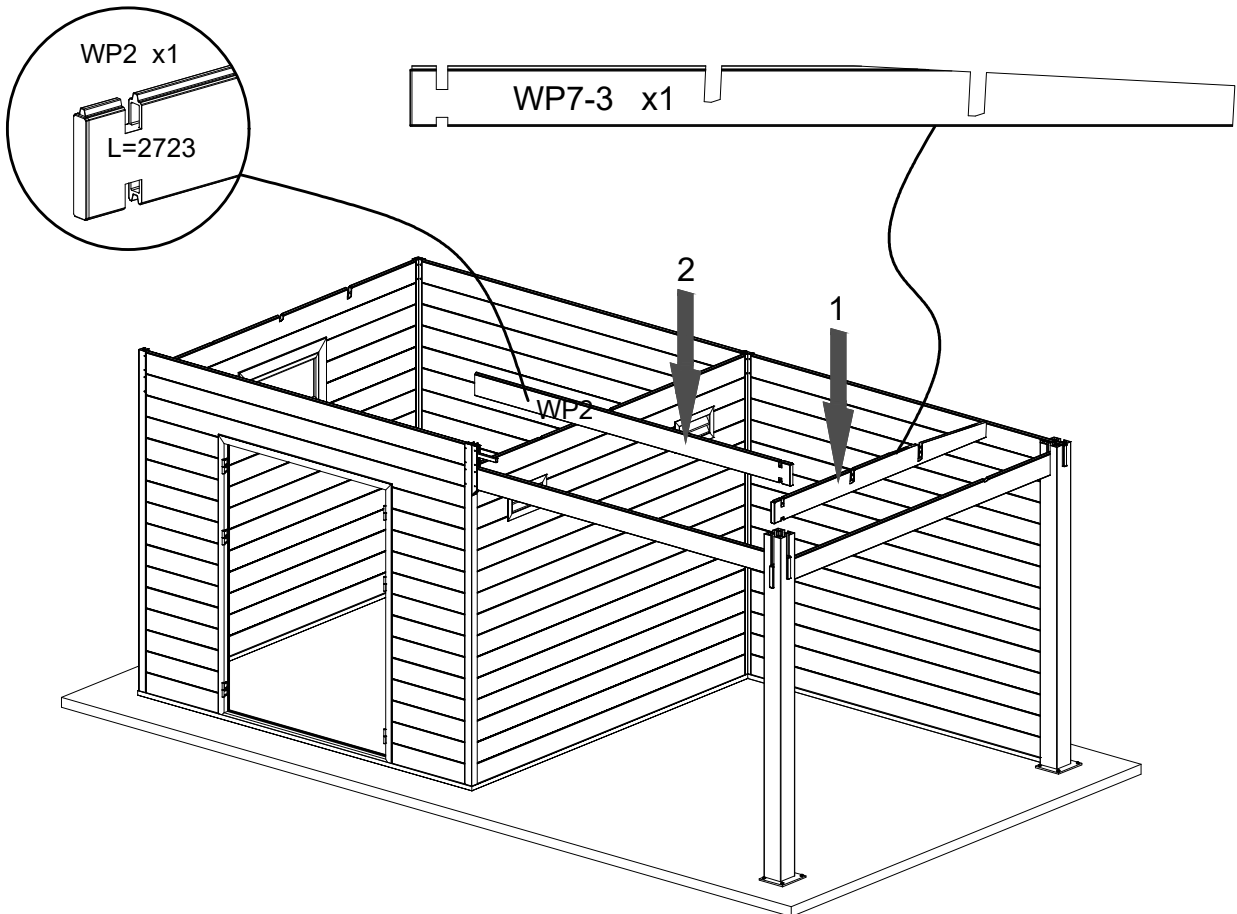

STEP 15 :

WP7 x1

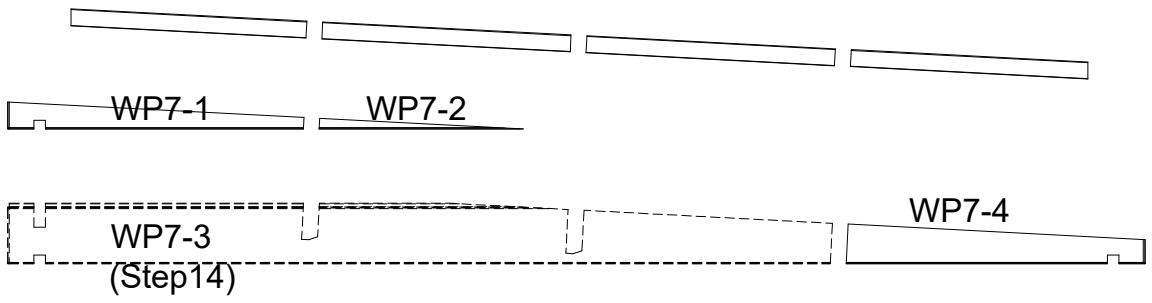

WP8 x2

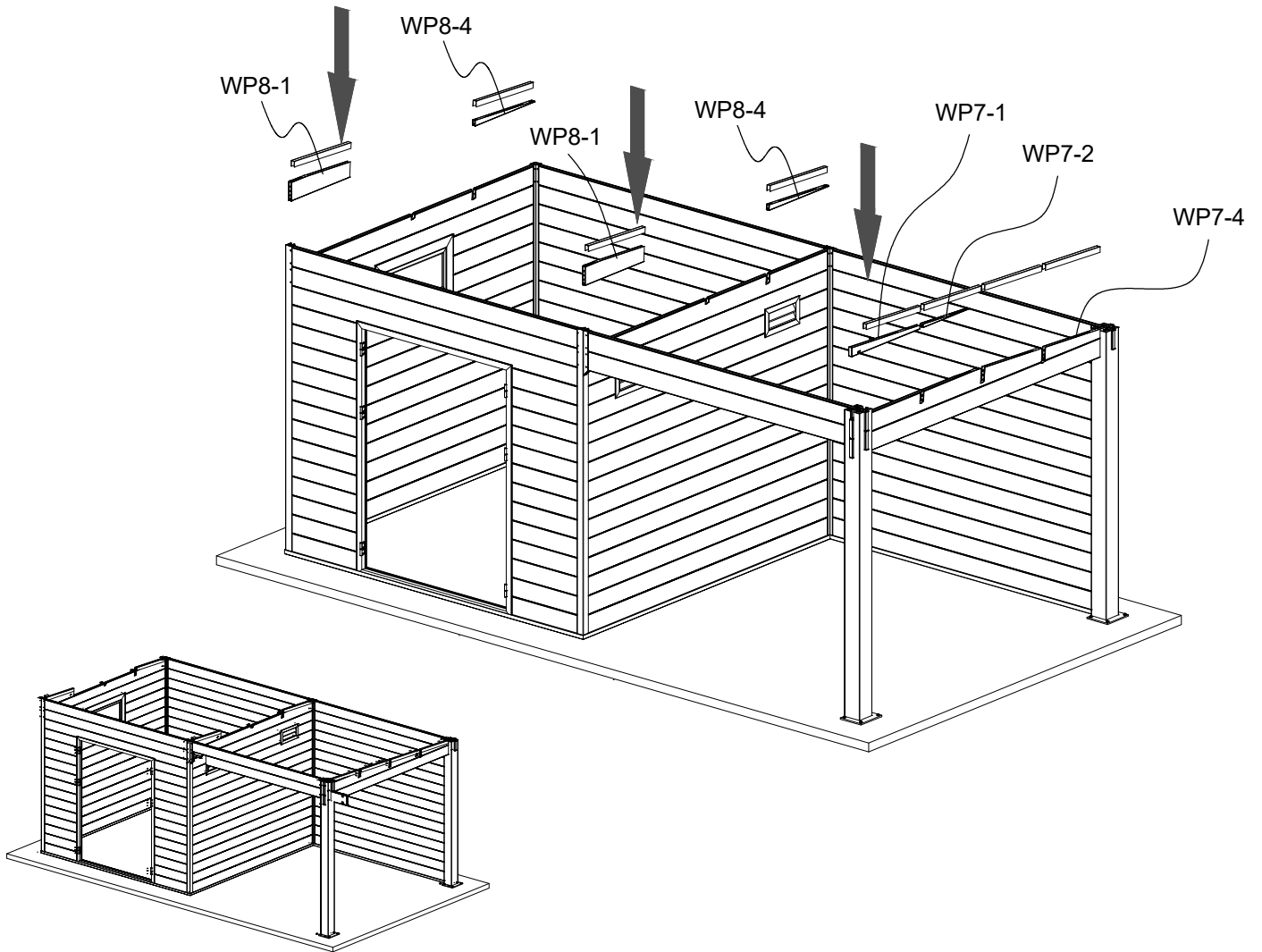
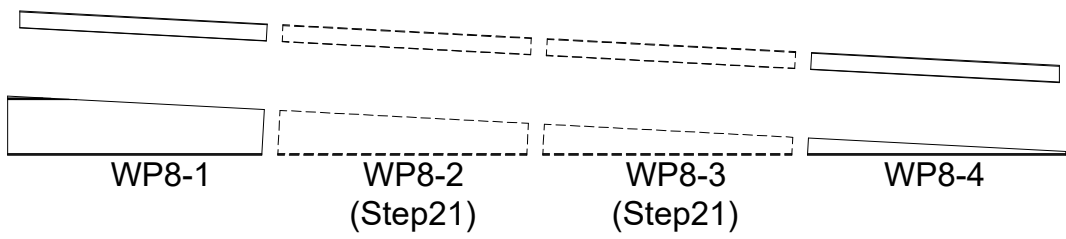

STEP 16 :

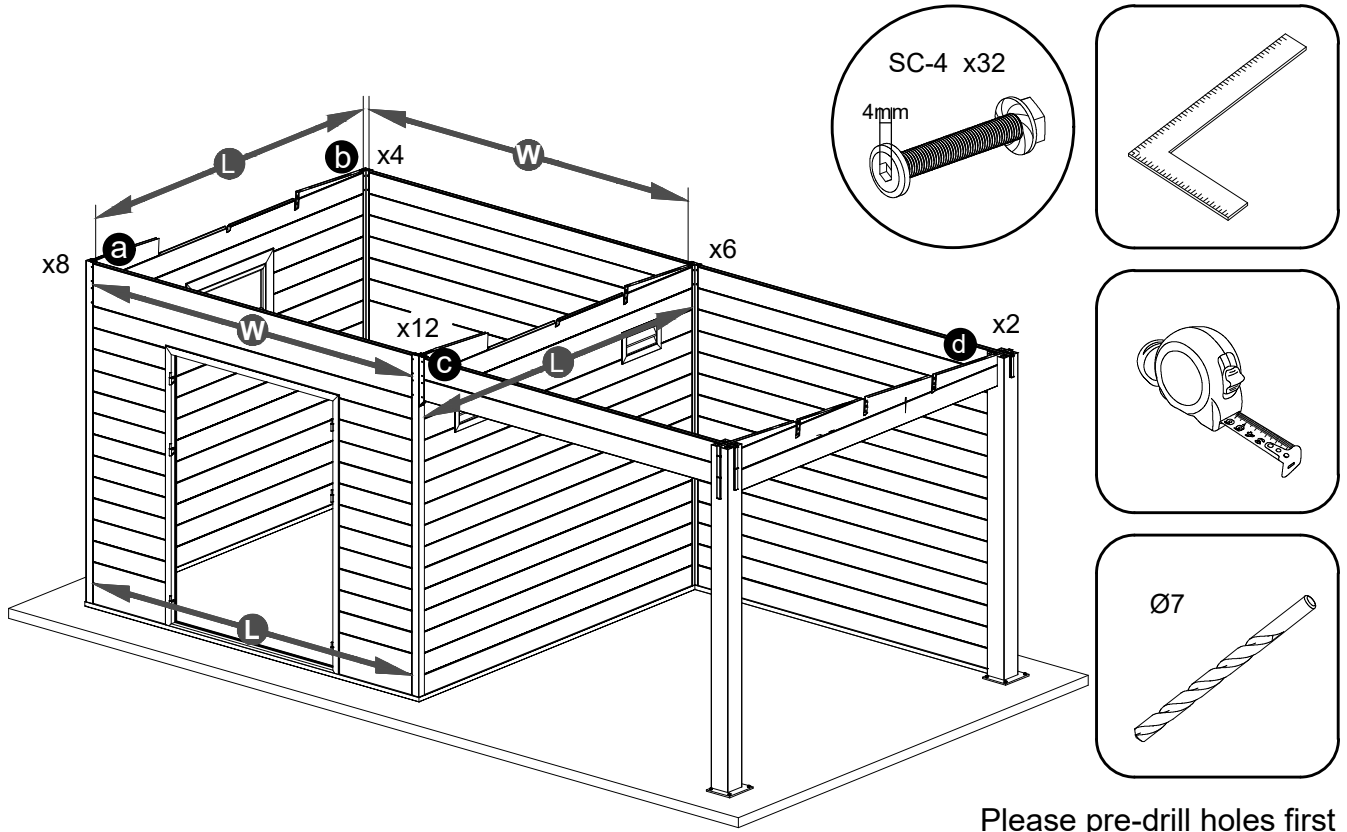

DETAIL :

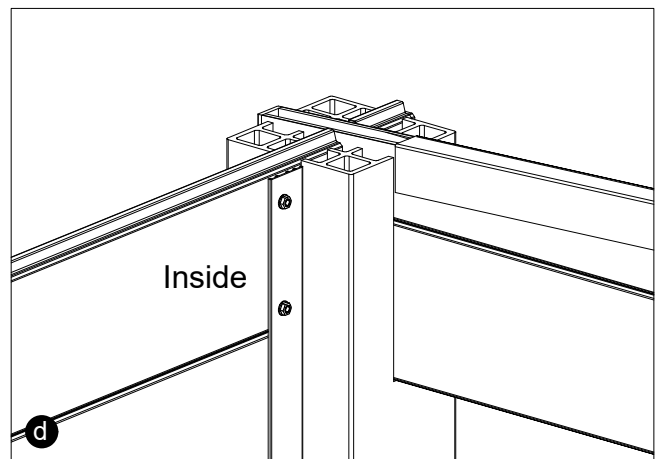
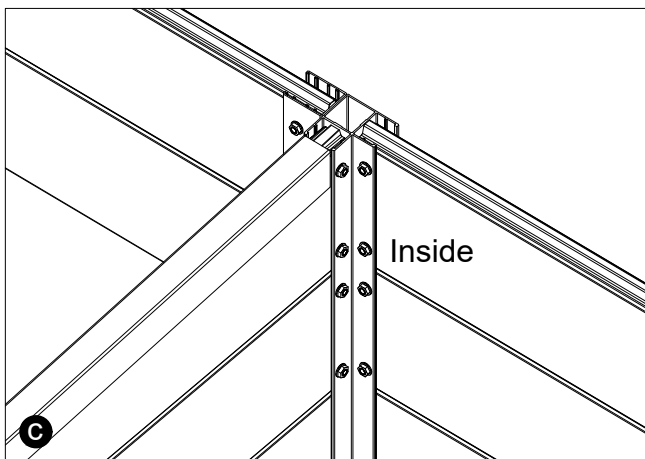
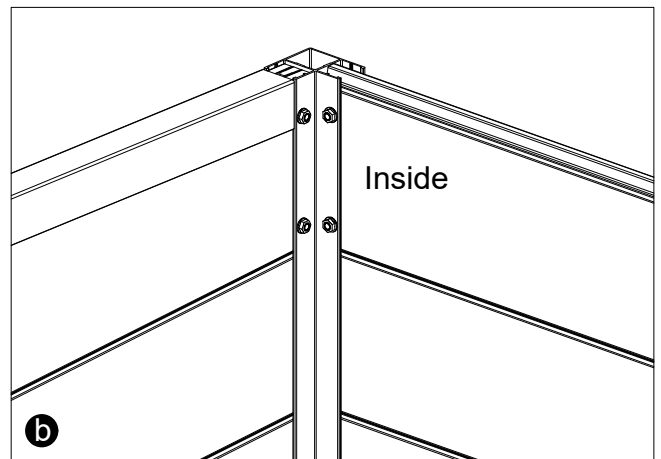
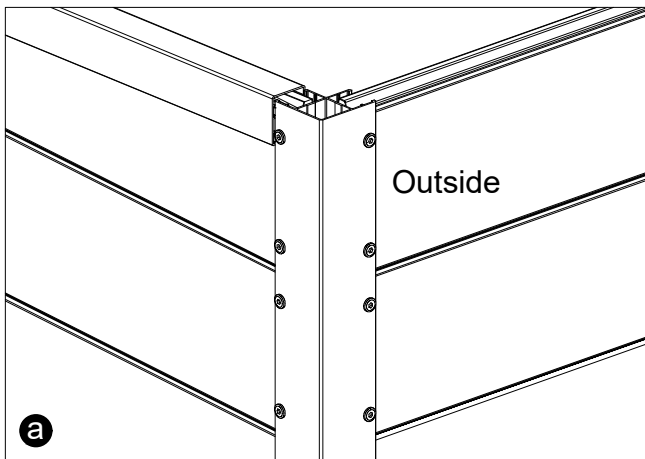

STEP 17 :

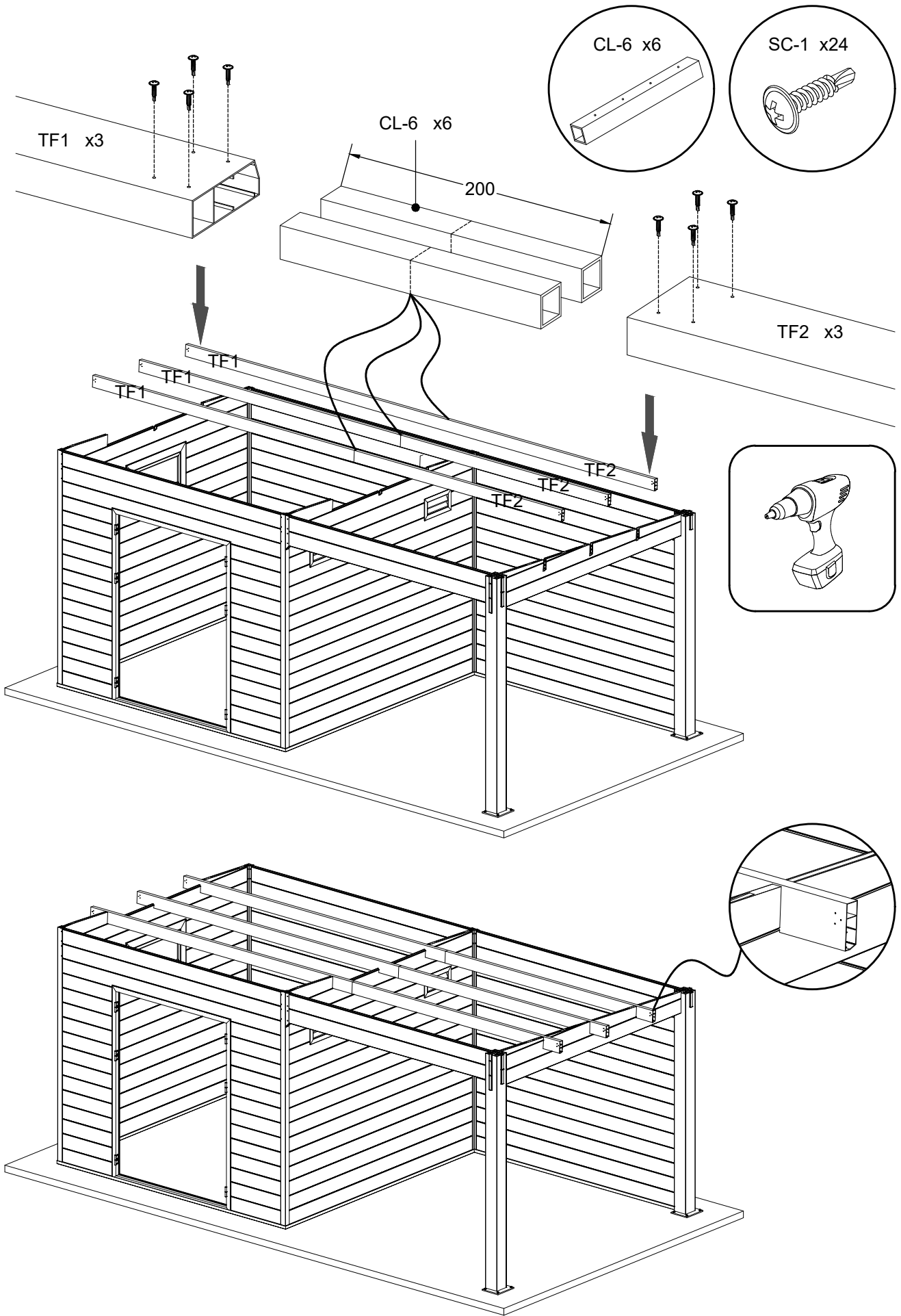

STEP 18 :

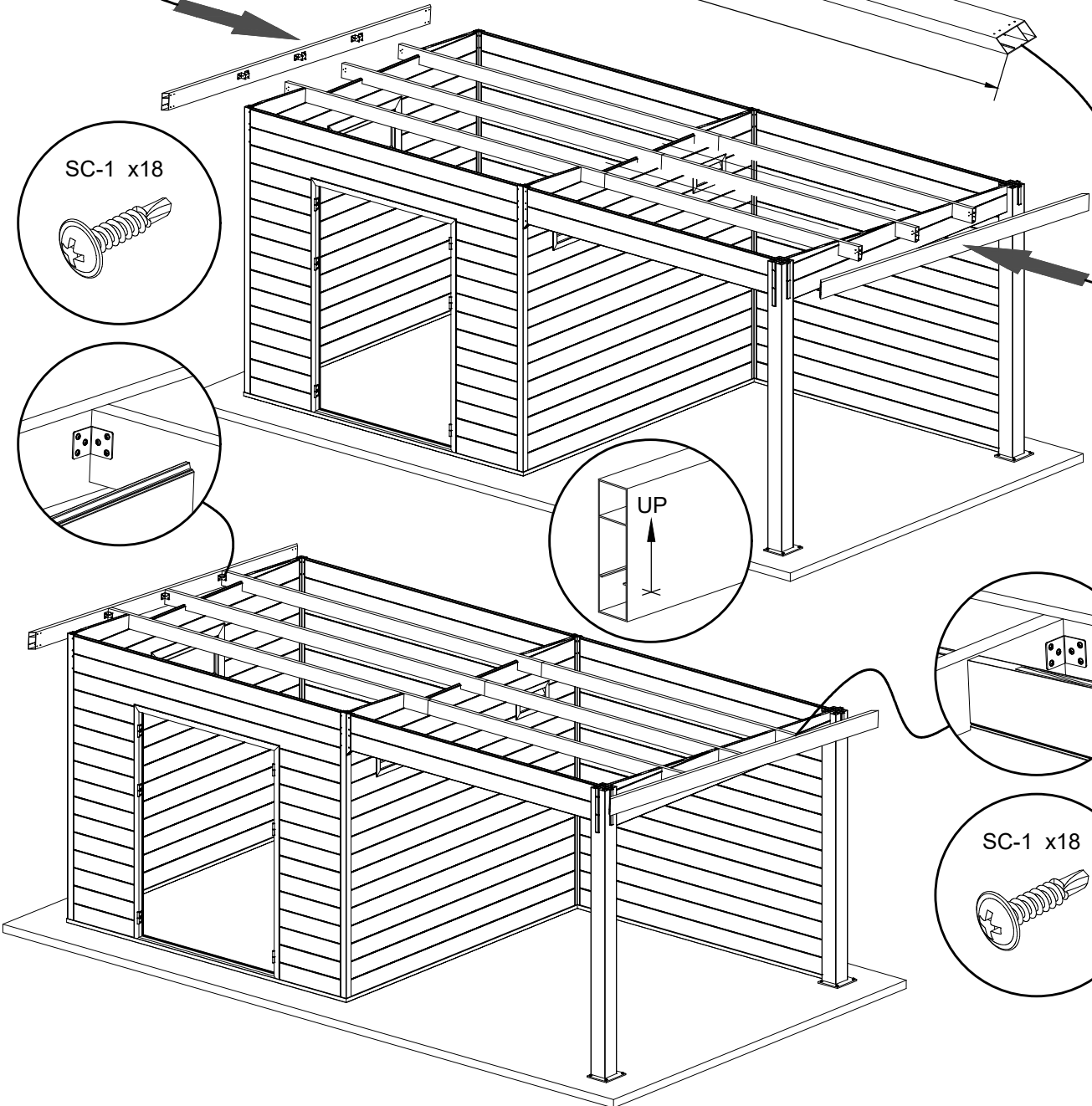
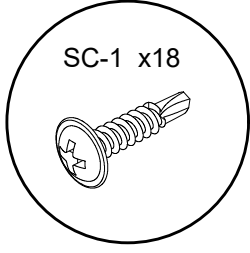
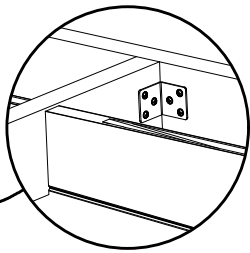
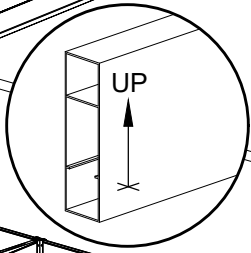
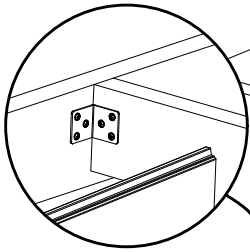
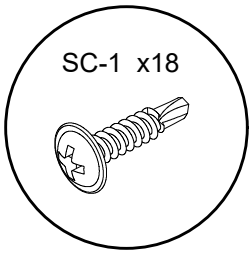
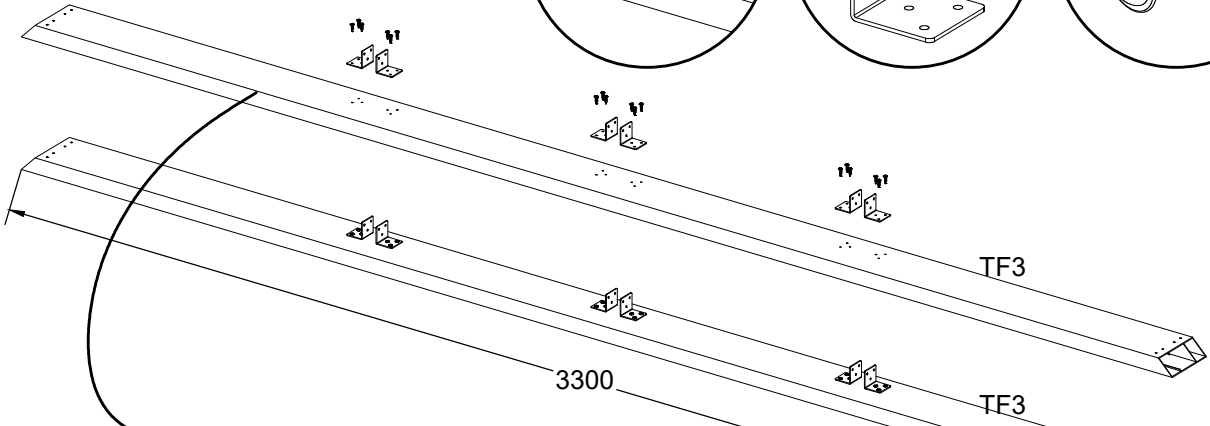
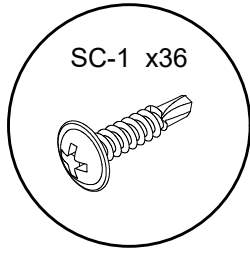
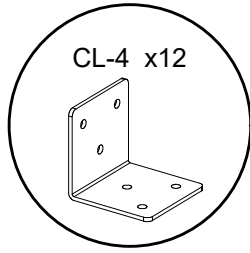
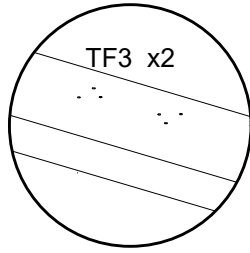

STEP 19 :

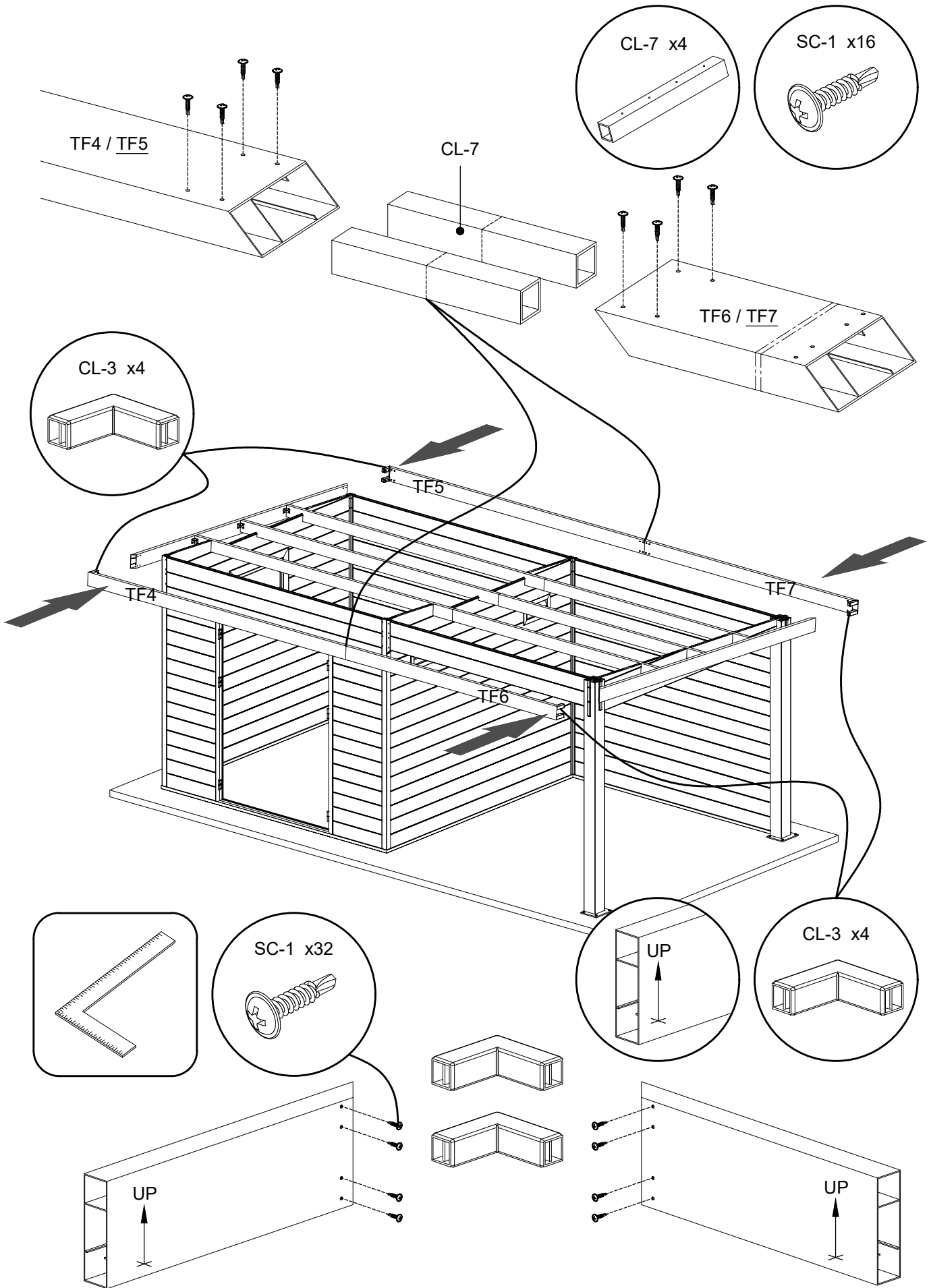

STEP 20 :

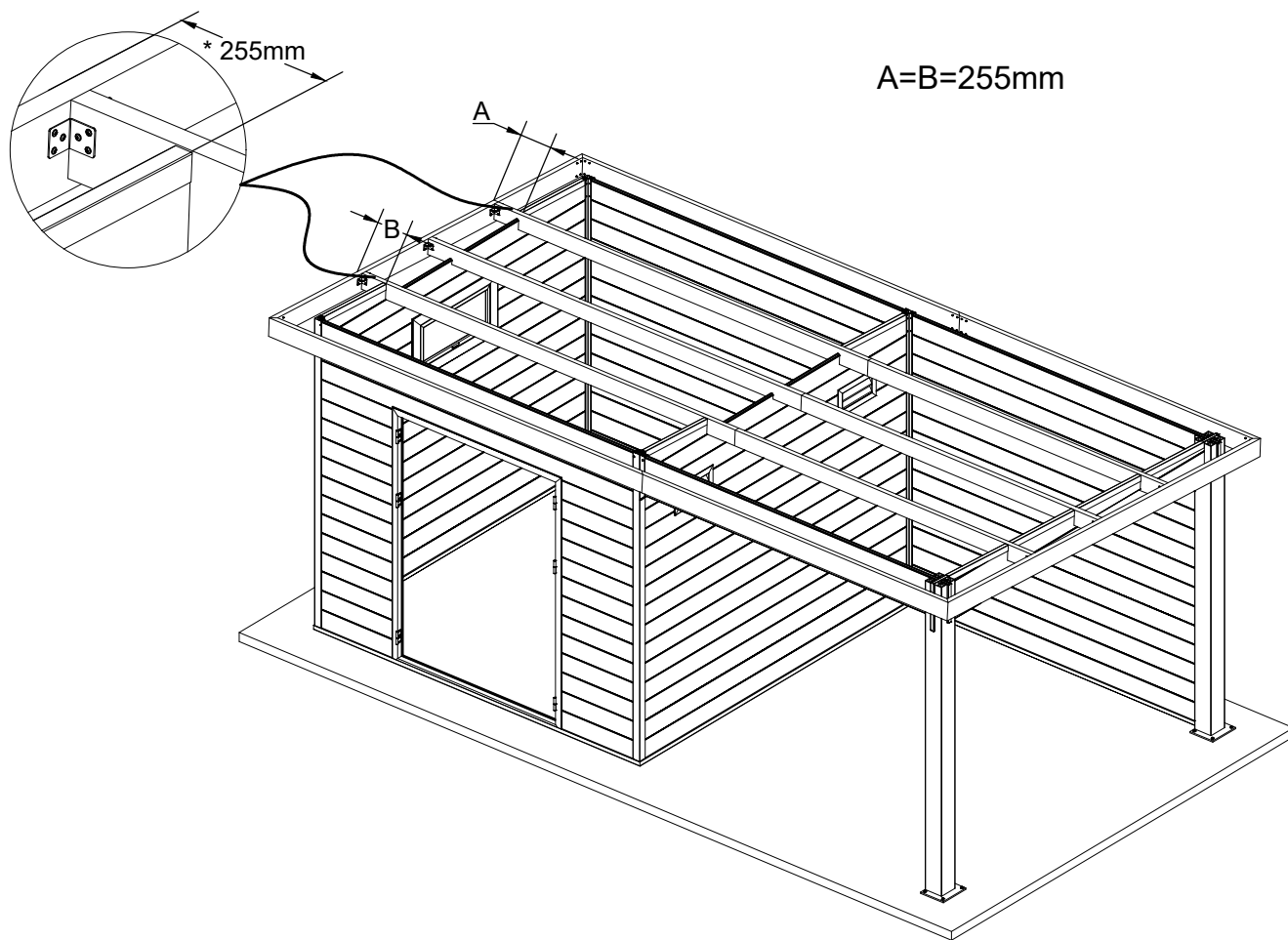

STEP 21 :

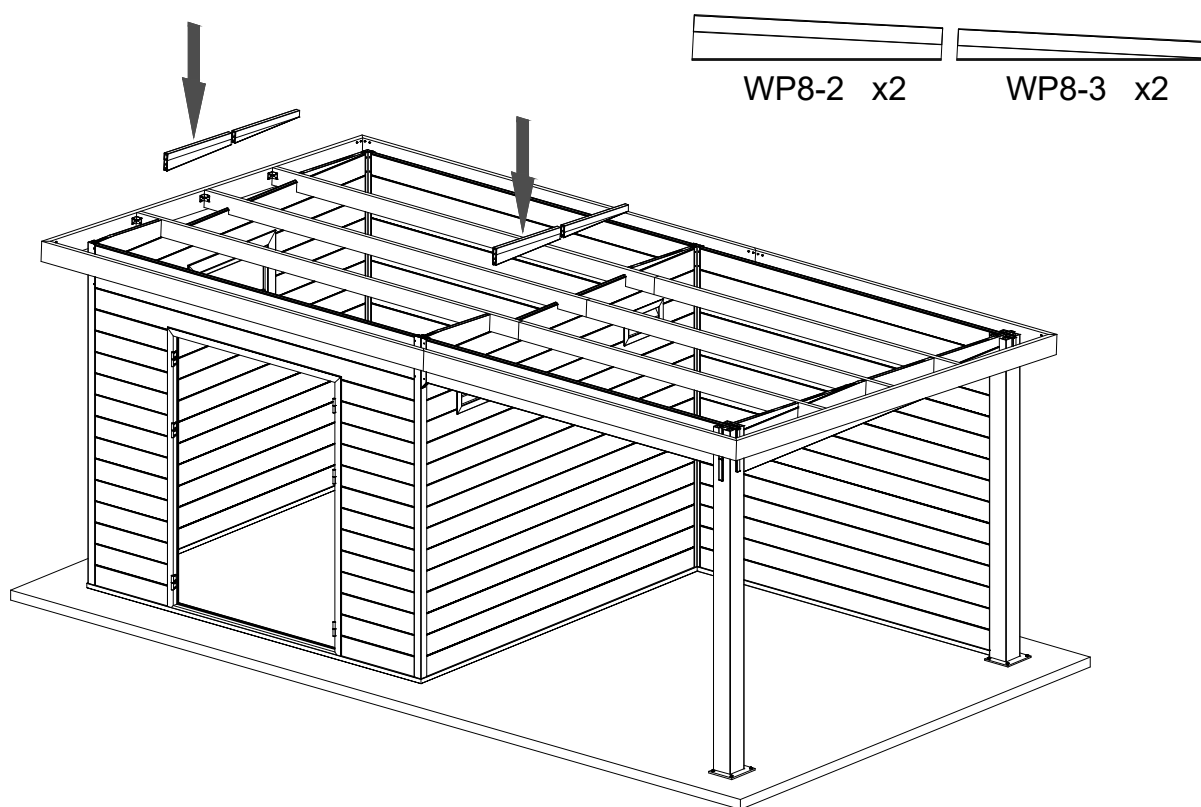

STEP 22 : Connecting Together

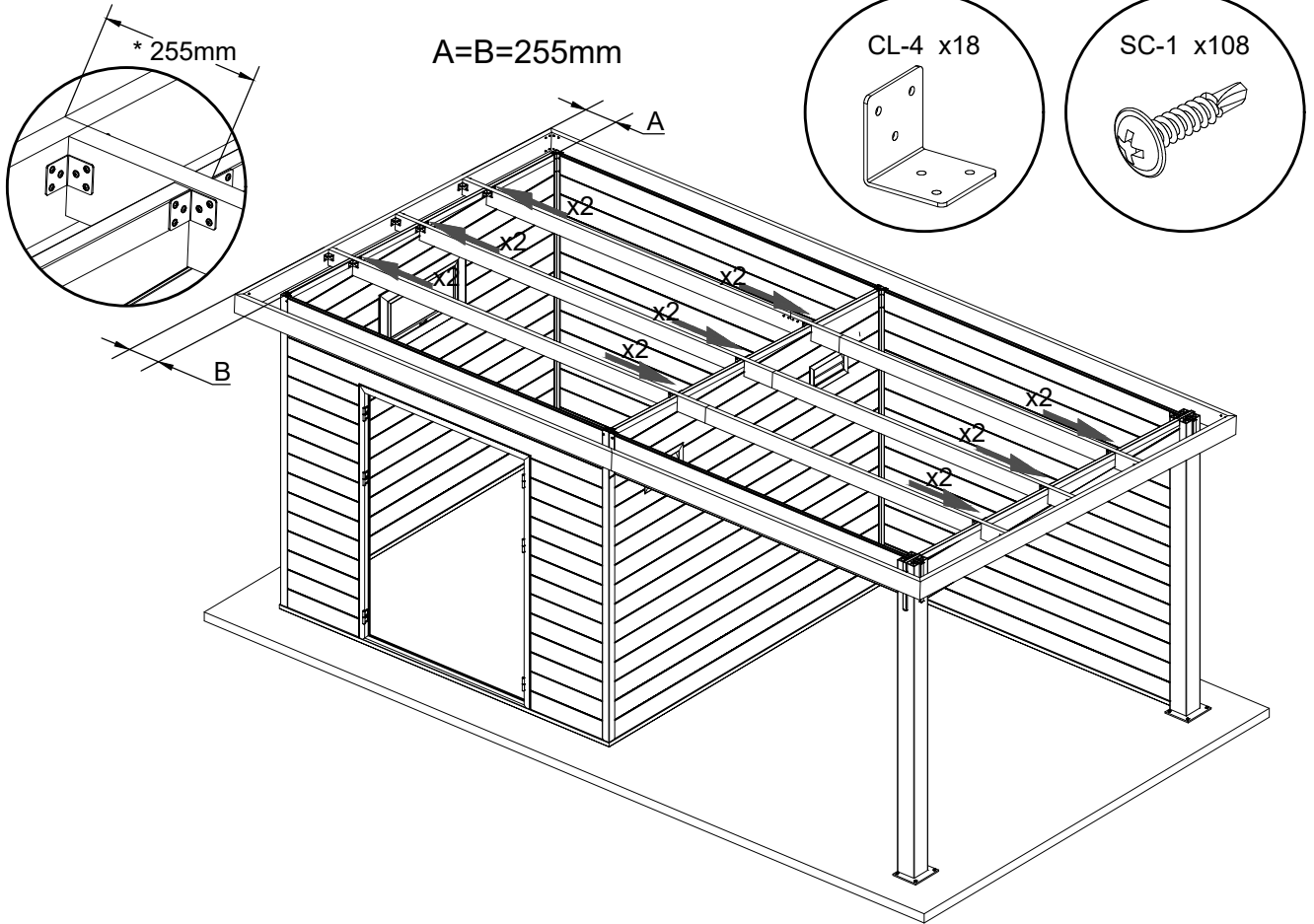

STEP 23 : Strengthening connections

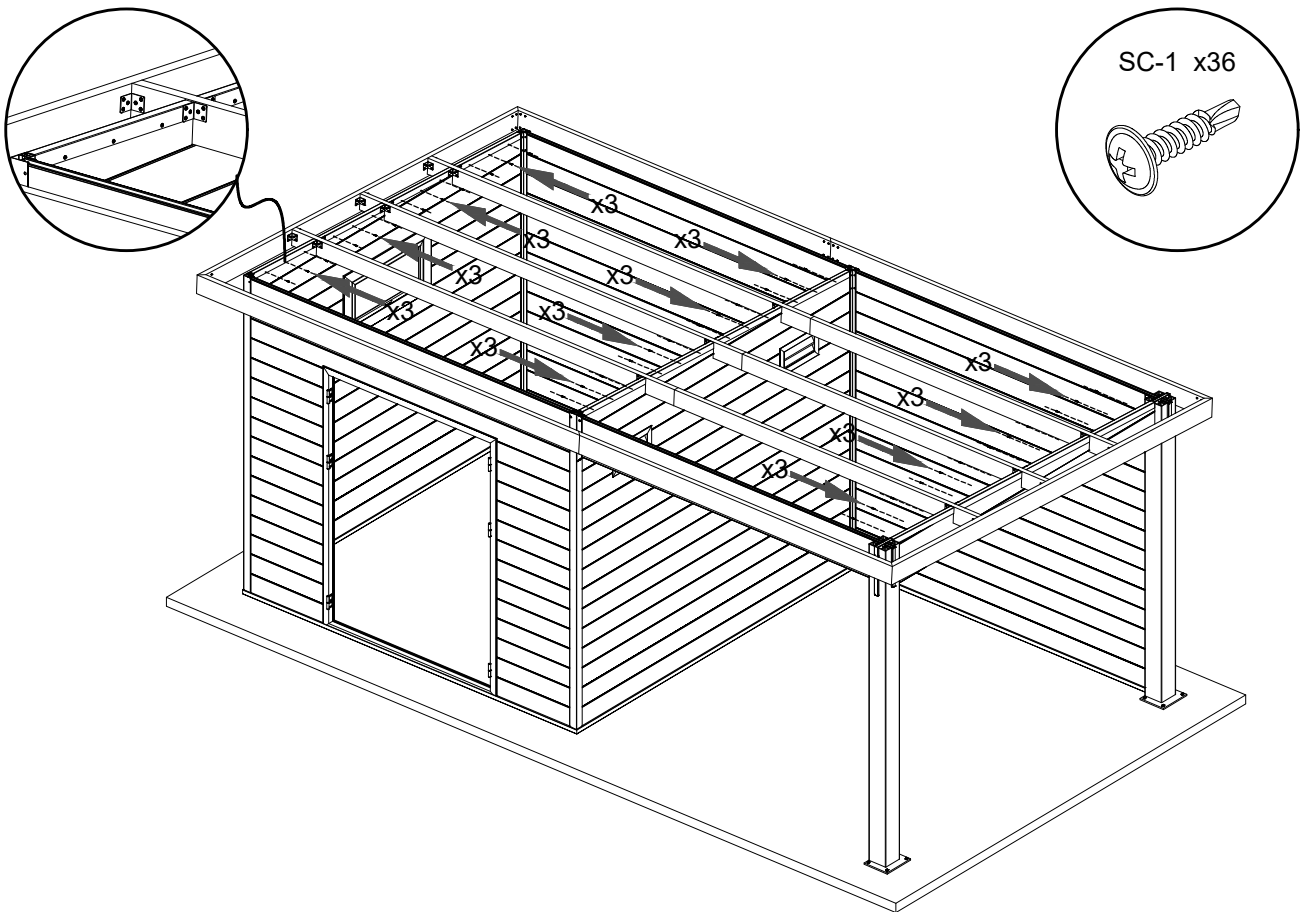

STEP 24 :

A = B = C

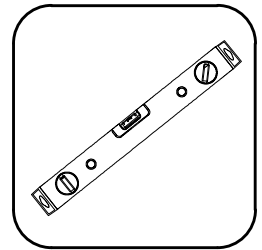
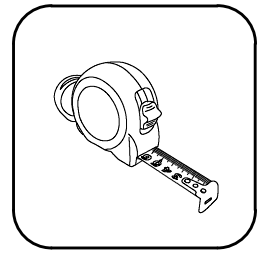
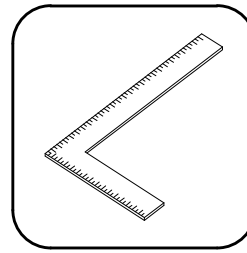
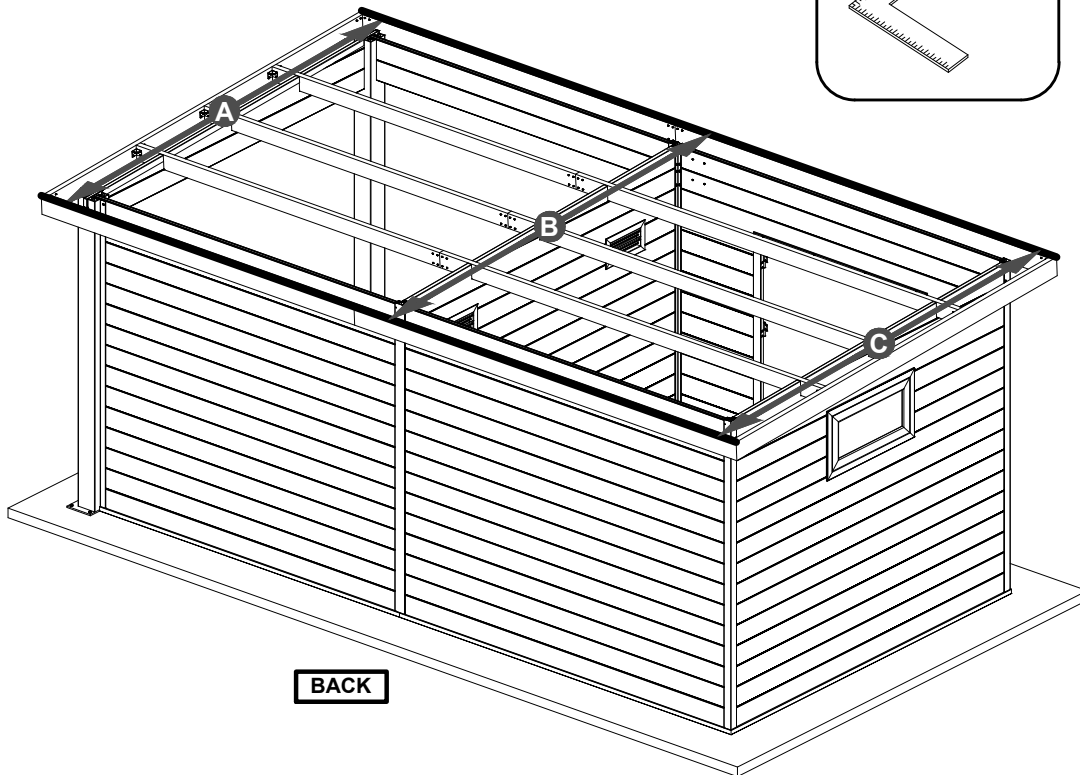

STEP 25 : The installation of top roof panel.

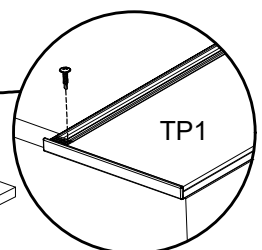
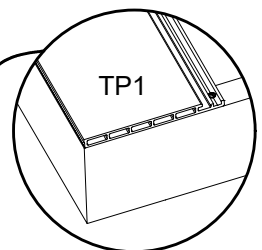
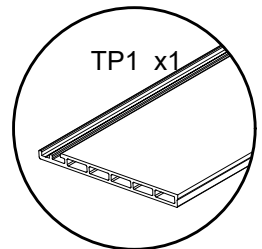
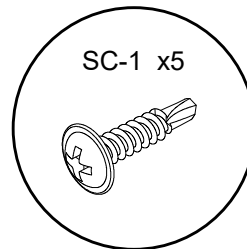
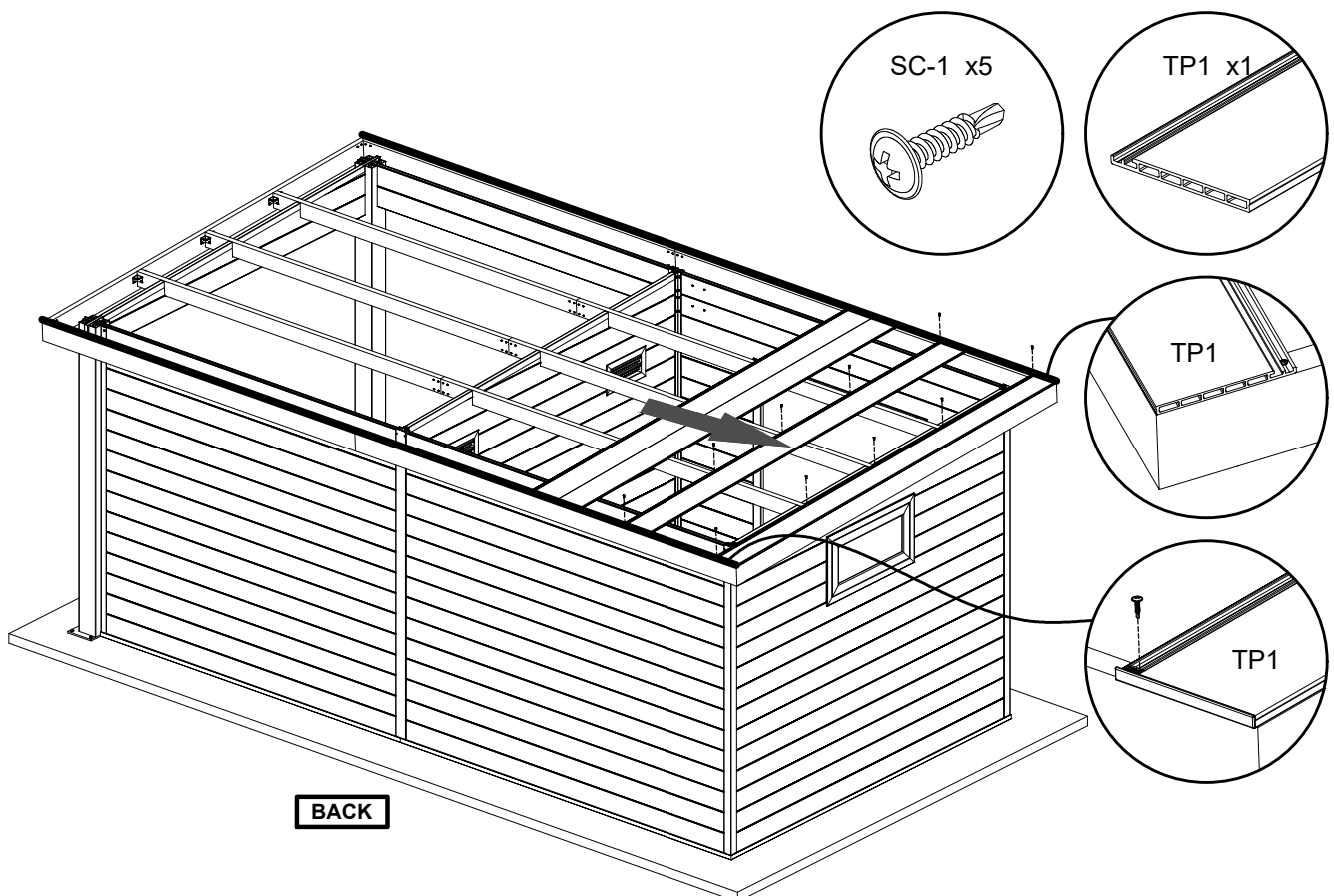

STEP 26 :

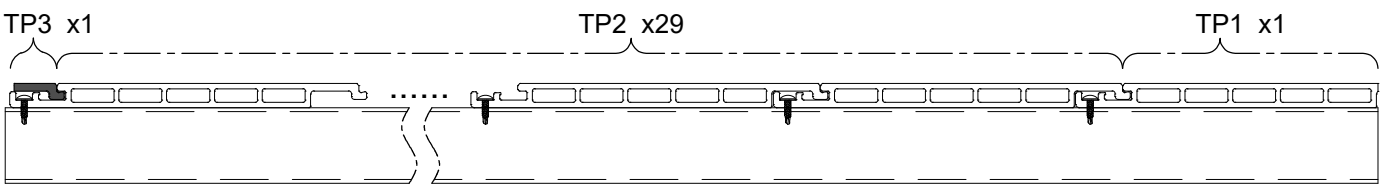
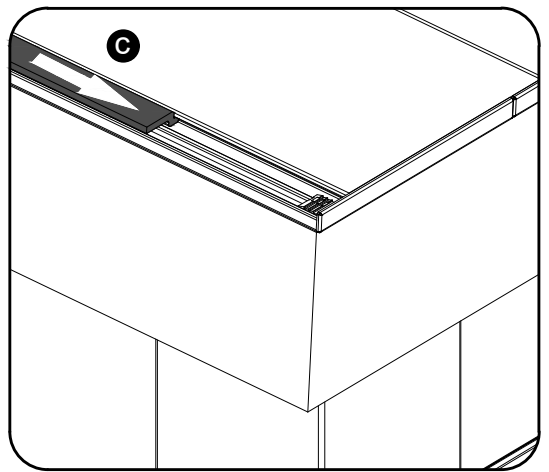
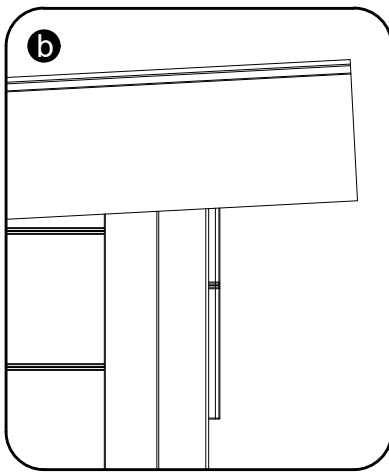
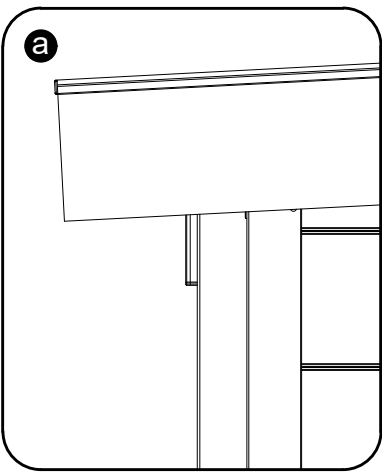
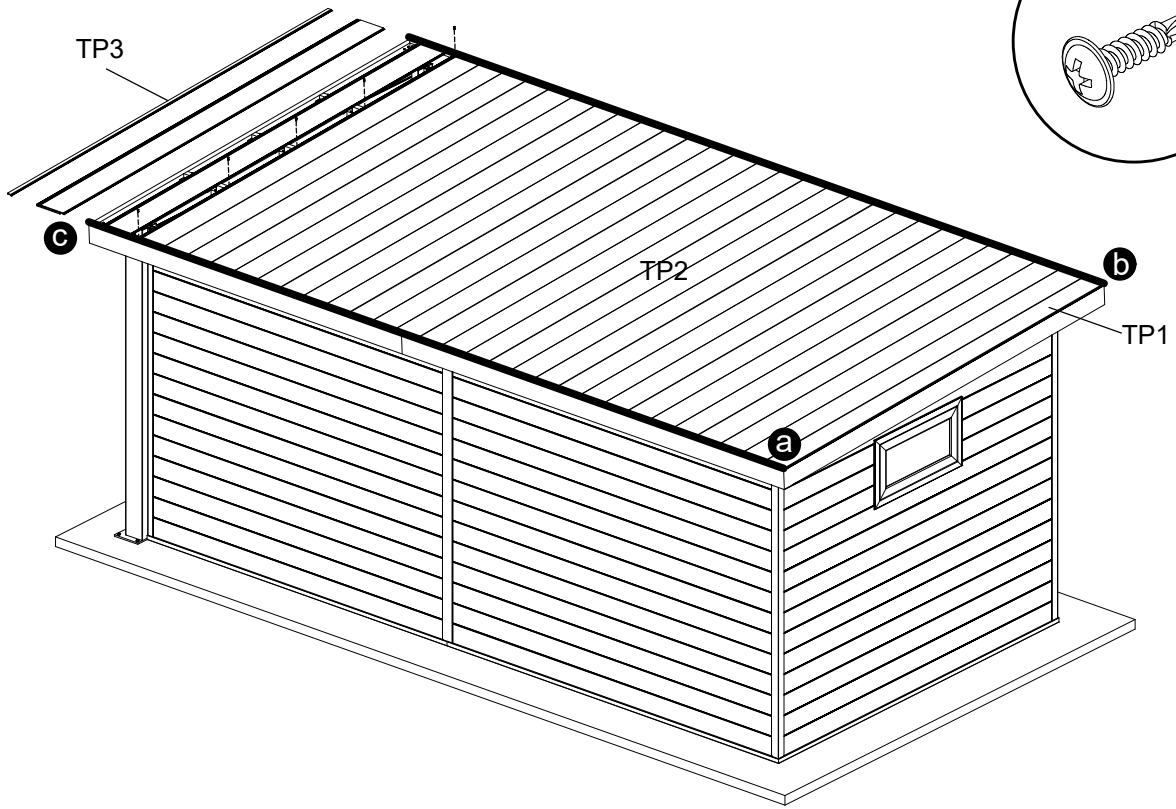
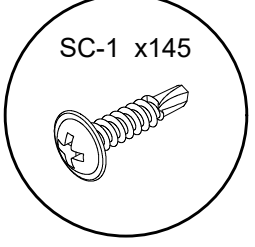
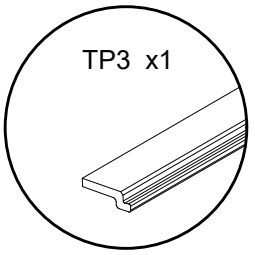
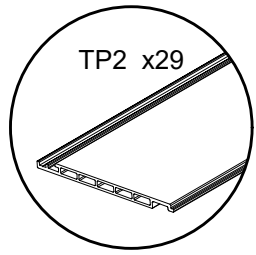
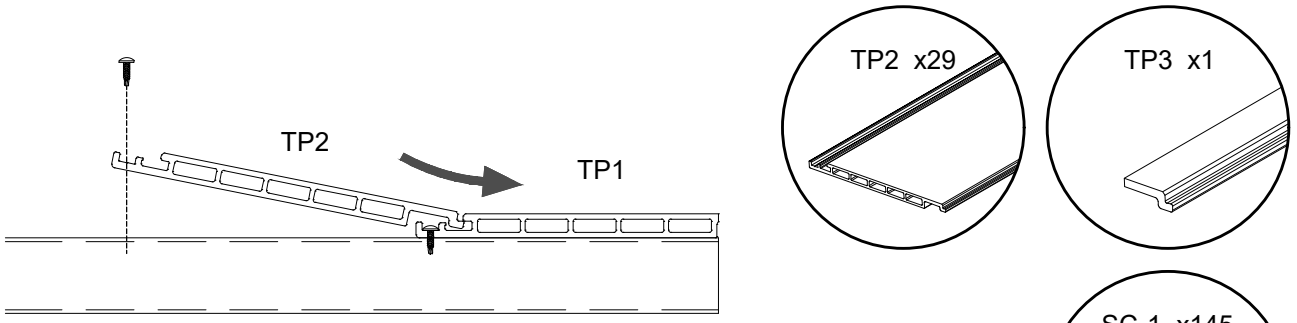

STEP 27:

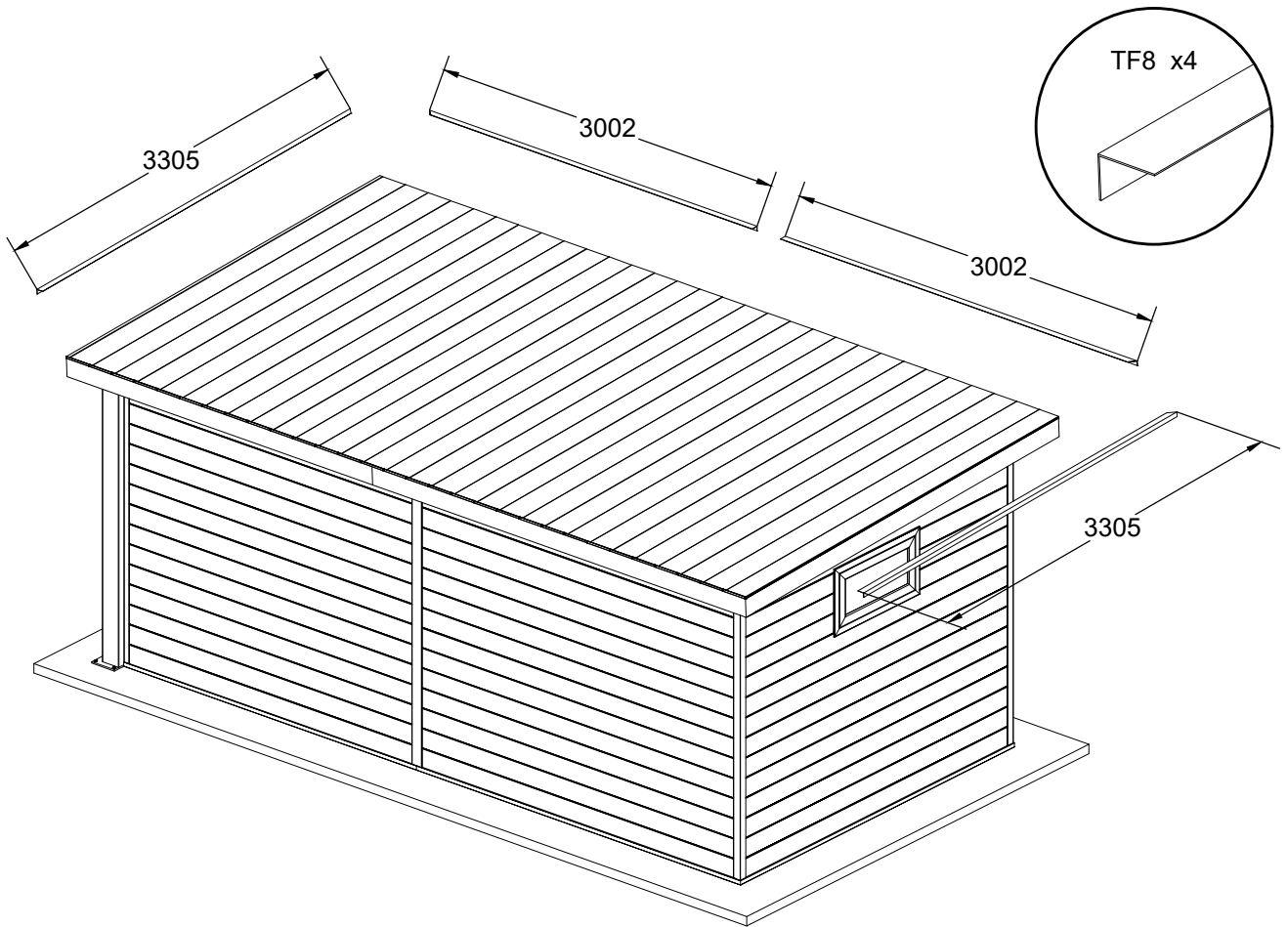

STEP 28 :

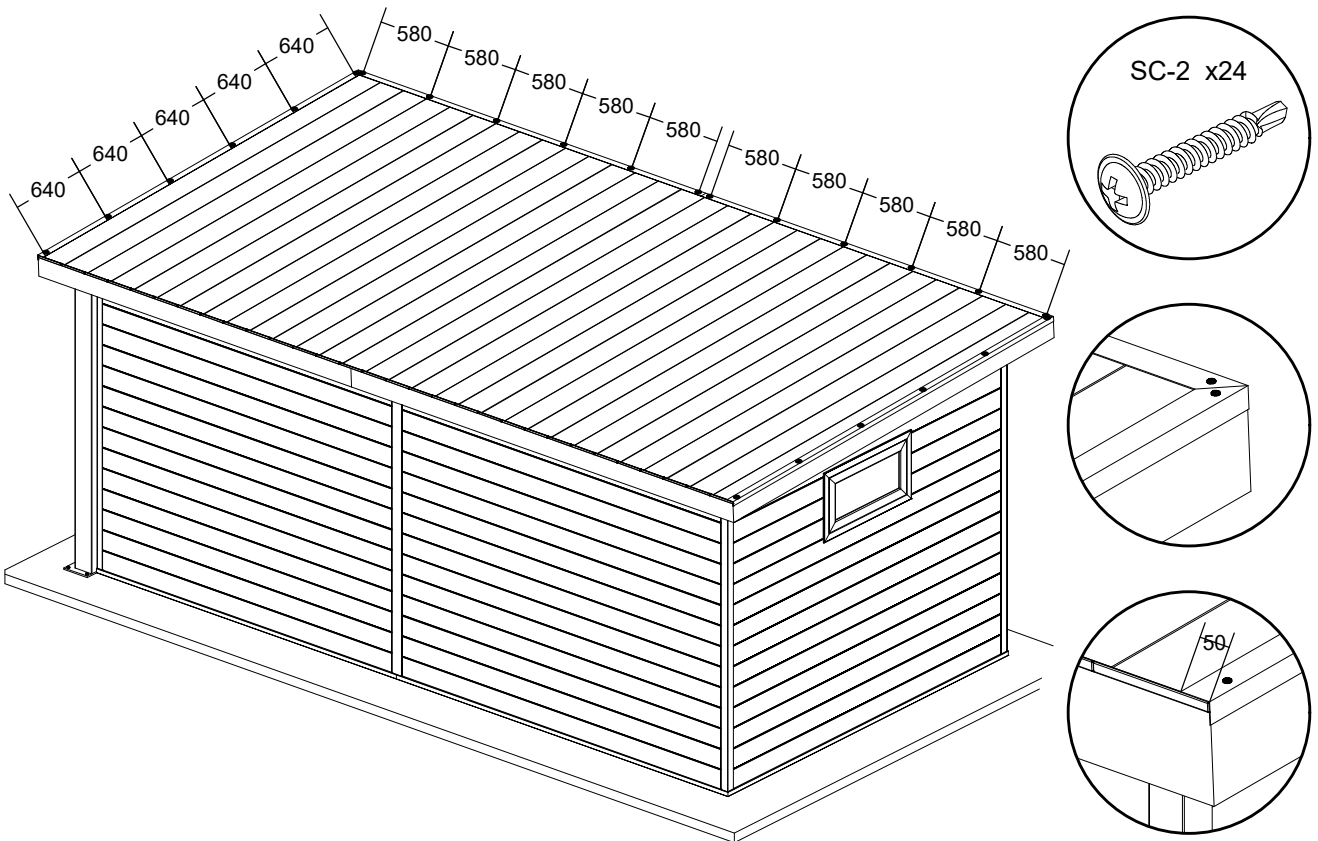

STEP 29 : DOOR and LOCK

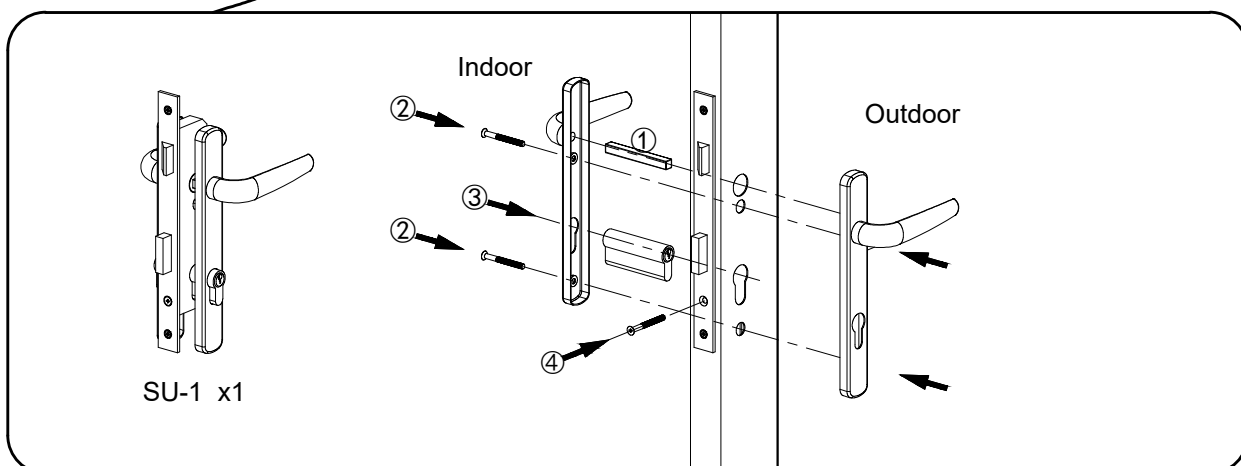
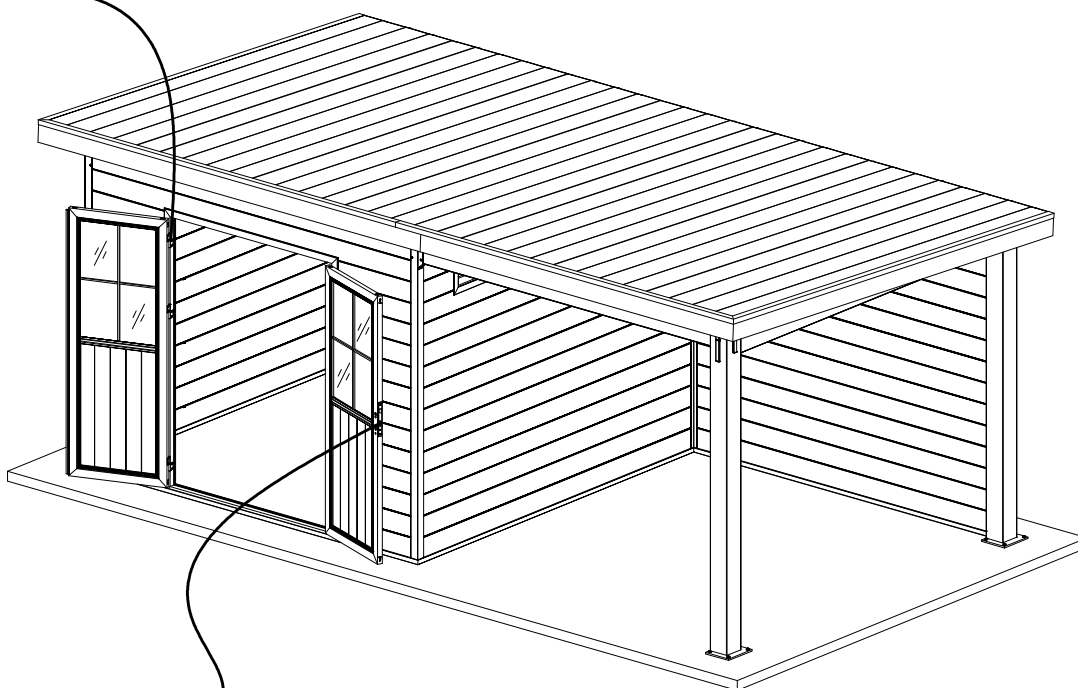
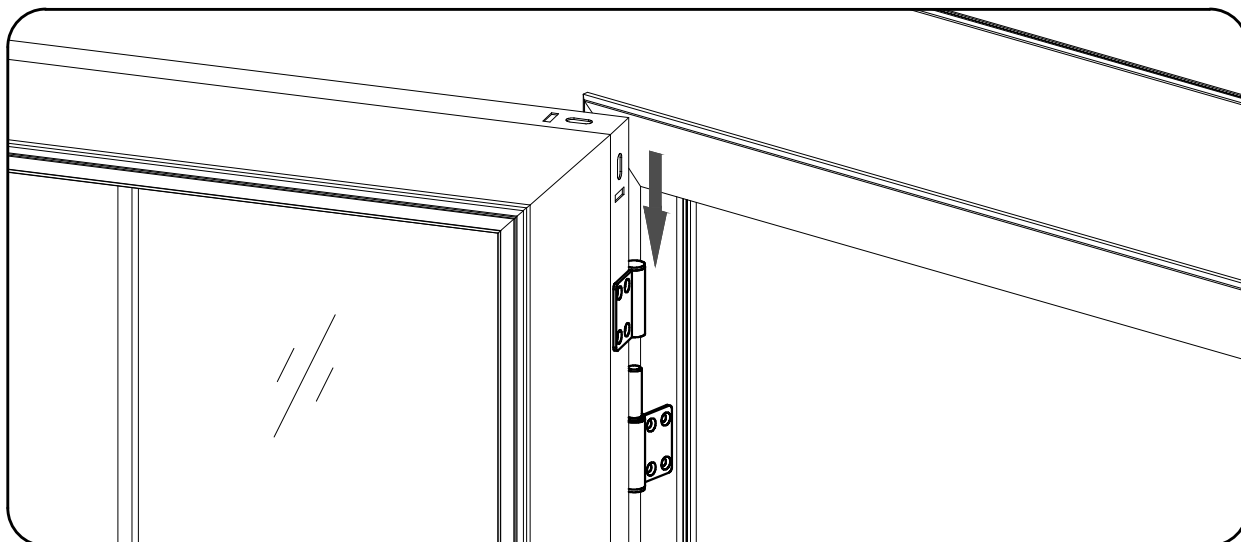

STEP 30 : Connecting Together

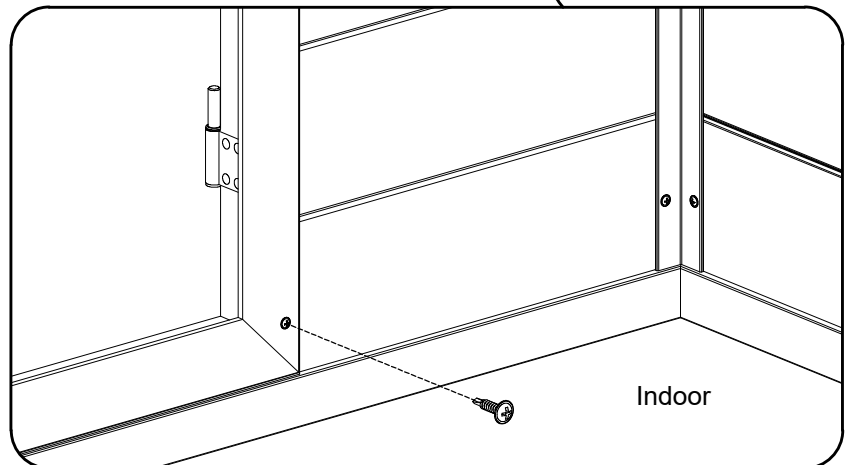
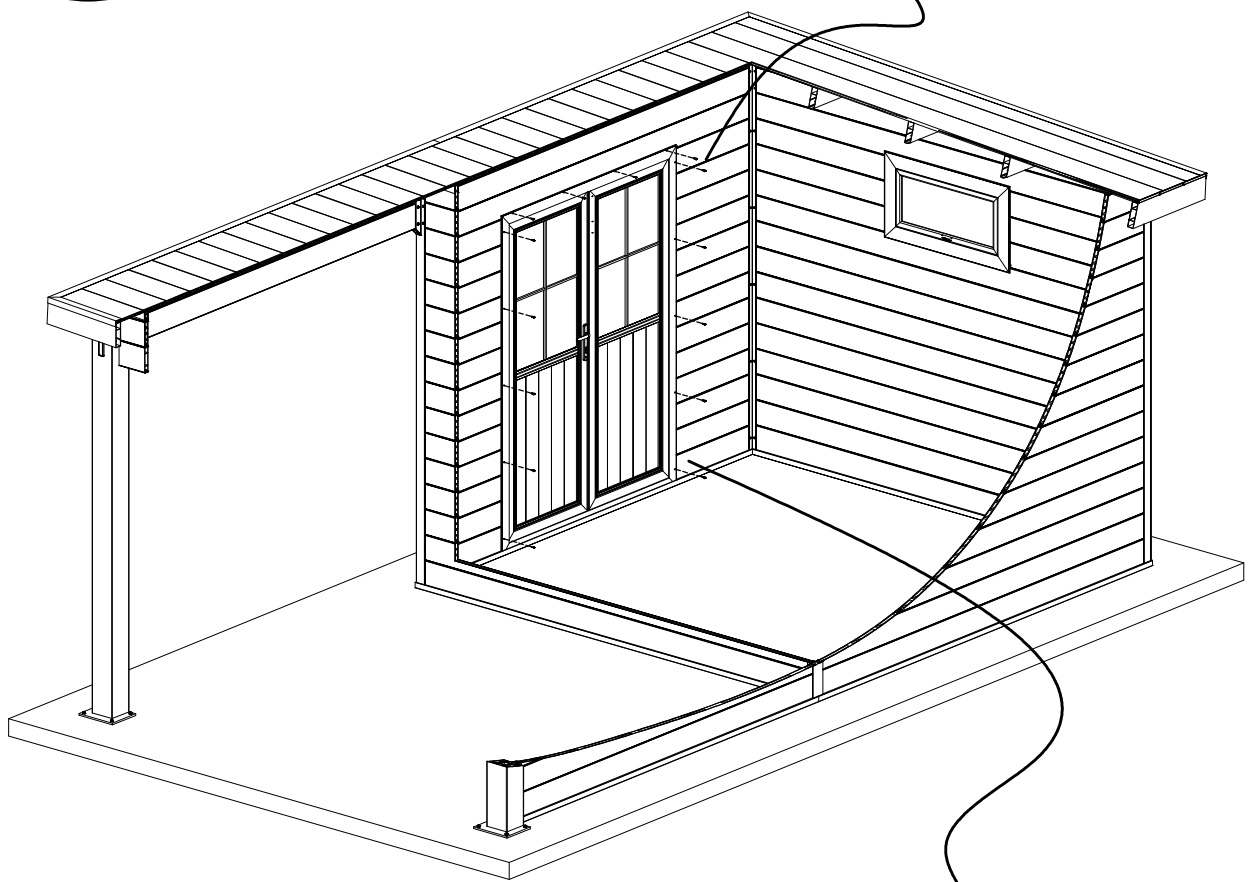
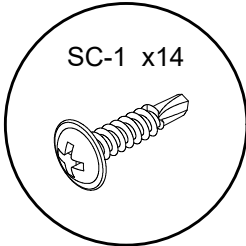
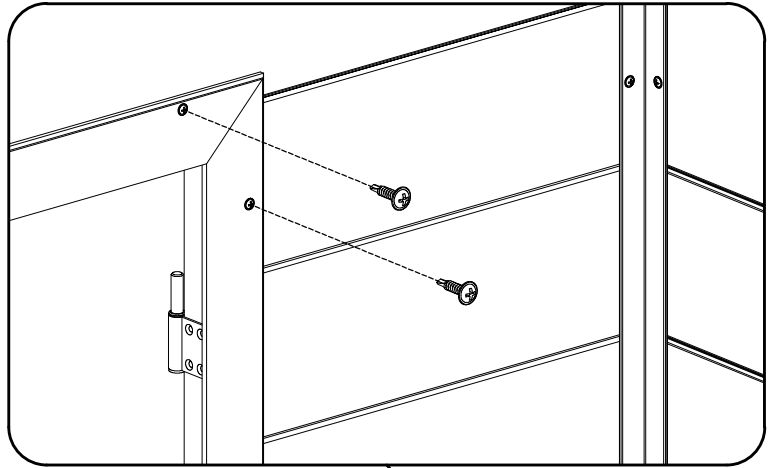
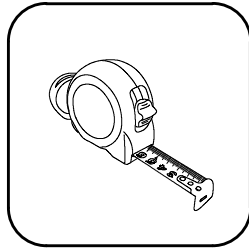
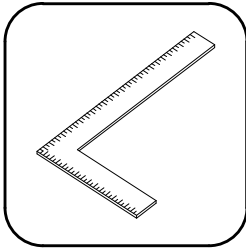

STEP 31 :

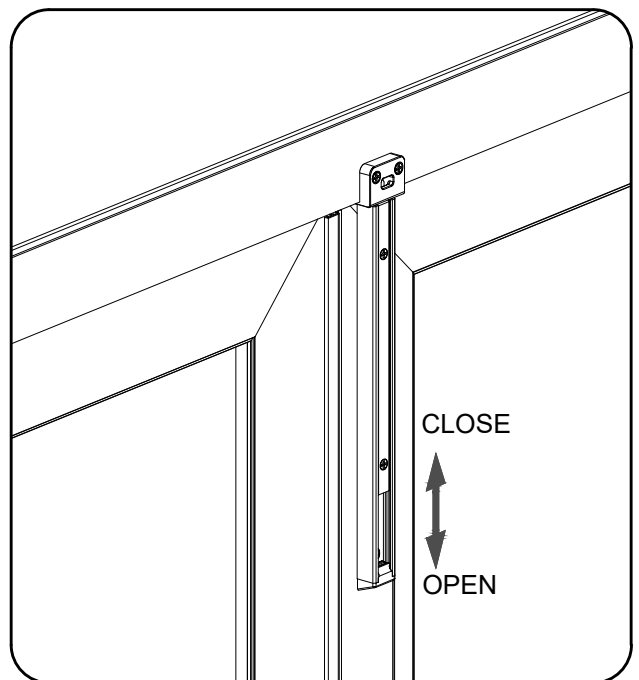
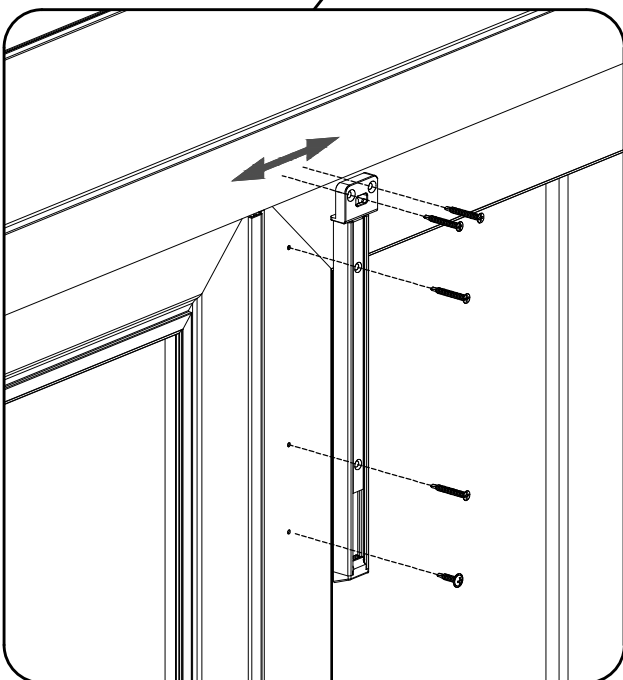
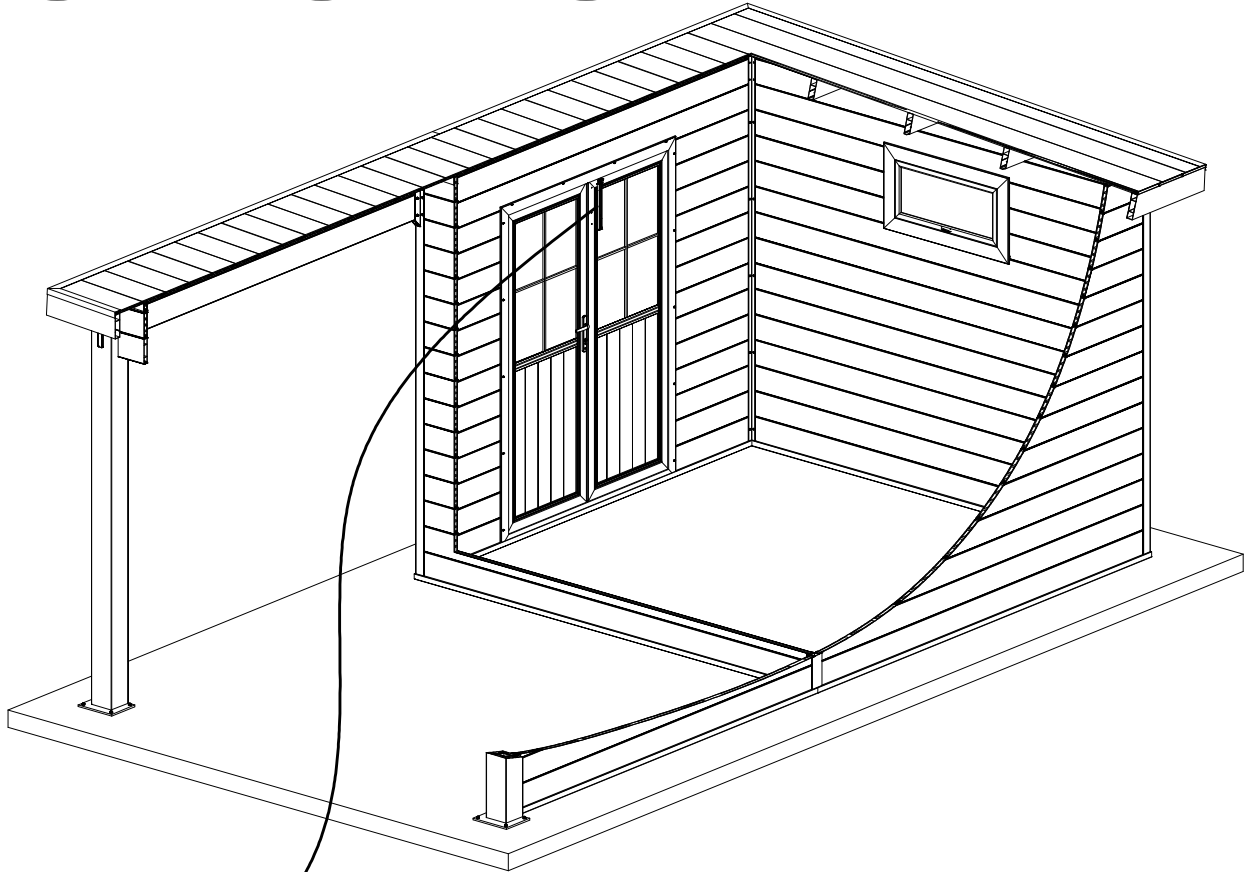
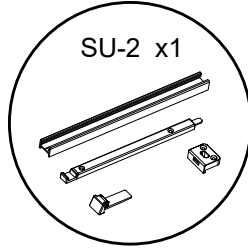
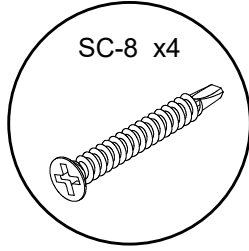
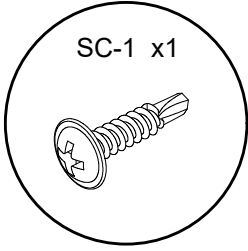

STEP 32 :

